

BS EN 55032:2015+A11:2020
Incorporating corrigendum June 2016



BSI Standards Publication

Electromagnetic compatibility of multimedia equipment – Emission Requirements

bsi.

National foreword

This British Standard is the UK implementation of EN 55032:2015+A11:2020. It is derived from CISPR 32:2015, incorporating corrigendum June 2016. It supersedes BS EN 55032:2015, which will be withdrawn on 27 November 2022.

The UK participation in its preparation was entrusted to Technical Committee GEL/210/11, EMC - Standards Committee.

A list of organizations represented on this committee can be obtained on request to its secretary.

This publication does not purport to include all the necessary provisions of a contract. Users are responsible for its correct application.

© The British Standards Institution 2020
Published by BSI Standards Limited 2020

ISBN 978 0 539 11929 9

ICS 33.100.10

Compliance with a British Standard cannot confer immunity from legal obligations.

This British Standard was published under the authority of the Standards Policy and Strategy Committee on 31 July 2015.

Amendments/corrigenda issued since publication

Date	Text affected
31 August 2016	Implementation of IEC corrigendum June 2016: Table B.1 corrected
31 March 2020	Implementation of CENELEC amendment A11:2020: Annex ZZ replaced

EUROPEAN STANDARD

EN 55032:2015+A11

NORME EUROPÉENNE

EUROPÄISCHE NORM

March 2020

ICS 33.100.10

Supersedes EN 55032:2012

English Version

**Electromagnetic compatibility of multimedia equipment -
Emission Requirements
(CISPR 32:2015)**

Compatibilité électromagnétique des équipements
multimédia - Exigences d'émission
(CISPR 32:2015)

Elektromagnetische Verträglichkeit von Multimediageräten
und -einrichtungen - Anforderungen an die Störaussendung
(CISPR 32:2015)

This European Standard was approved by CENELEC on 2015-05-05. CENELEC members are bound to comply with the CEN/CENELEC Internal Regulations which stipulate the conditions for giving this European Standard the status of a national standard without any alteration.

Up-to-date lists and bibliographical references concerning such national standards may be obtained on application to the CEN-CENELEC Management Centre or to any CENELEC member.

This European Standard exists in three official versions (English, French, German). A version in any other language made by translation under the responsibility of a CENELEC member into its own language and notified to the CEN-CENELEC Management Centre has the same status as the official versions.

CENELEC members are the national electrotechnical committees of Austria, Belgium, Bulgaria, Croatia, Cyprus, the Czech Republic, Denmark, Estonia, Finland, Former Yugoslav Republic of Macedonia, France, Germany, Greece, Hungary, Iceland, Ireland, Italy, Latvia, Lithuania, Luxembourg, Malta, the Netherlands, Norway, Poland, Portugal, Romania, Slovakia, Slovenia, Spain, Sweden, Switzerland, Turkey and the United Kingdom.



European Committee for Electrotechnical Standardization
Comité Européen de Normalisation Electrotechnique
Europäisches Komitee für Elektrotechnische Normung

CEN-CENELEC Management Centre: Avenue Marnix 17, B-1000 Brussels

European Foreword

The text of document CIS/1/498/FDIS, future edition 2 of CISPR 32, prepared by CISPR SC 1 "Electromagnetic compatibility of information technology equipment, multimedia equipment and receivers" was submitted to the IEC-CENELEC parallel vote and approved by CENELEC as EN 55032:2015.

The following dates are fixed:

- latest date by which the document has to be implemented at national level by publication of an identical national standard or by endorsement (dop) 2016-02-05
- latest date by which the national standards conflicting with the document have to be withdrawn (dow) 2018-05-05

This document supersedes EN 55032:2012.

Attention is drawn to the possibility that some of the elements of this document may be the subject of patent rights. CENELEC [and/or CEN] shall not be held responsible for identifying any or all such patent rights.

This document has been prepared under a mandate given to CENELEC by the European Commission and the European Free Trade Association, and supports essential requirements of EU Directive.

For the relationship with EU Directive see informative Annex ZZ, which is an integral part of this document.

Endorsement notice

The text of the International Standard CISPR 32:2015 was approved by CENELEC as a European Standard without any modification.

In the official version, for Bibliography, the following notes have to be added for the standards indicated:

CISPR 13:2009	NOTE	Harmonized as EN 55013:2013 (modified).
CISPR 16 Series	NOTE	Harmonized as EN 55016 Series.
CISPR 22:2008	NOTE	Harmonized as EN 55022:2010 (modified).

European foreword to amendment A11

This document (EN 55032:2015/A11:2020) has been prepared by CLC/TC 210 "Electromagnetic Compatibility (EMC)".

The following dates are fixed:

- latest date by which this document has to be implemented at national level by publication of an identical national standard or by endorsement (dop) 2020-11-27
- latest date by which the national standards conflicting with this document have to be withdrawn (dow) 2022-11-27

This document amends EN 55032:2015.

Attention is drawn to the possibility that some of the elements of this document may be the subject of patent rights. CENELEC shall not be held responsible for identifying any or all such patent rights.

This document has been prepared under a mandate given to CENELEC by the European Commission and the European Free Trade Association, and supports essential requirements of EU Directive(s).

For the relationship with EU Directive(s) see informative Annex ZZ, which is an integral part of this document.

Annex ZA
(normative)

**Normative references to international publications
with their corresponding European publications**

The following documents, in whole or in part, are normatively referenced in this document and are indispensable for its application. For dated references, only the edition cited applies. For undated references, the latest edition of the referenced document (including any amendments) applies.

NOTE 1 When an International Publication has been modified by common modifications, indicated by (mod), the relevant EN/HD applies.

NOTE 2 Up-to-date information on the latest versions of the European Standards listed in this annex is available here: www.cenelec.eu

<u>Publication</u>	<u>Year</u>	<u>Title</u>	<u>EN/HD</u>	<u>Year</u>
CISPR 16-1-1	2010	Specification for radio disturbance and immunity measuring apparatus and methods - Part 1-1: Radio disturbance and immunity measuring apparatus - Measuring apparatus	EN 55016-1-1	2010
+A1	2010		+A1	2010
+A2	2014		+A2	2014
CISPR 16-1-2	2003	Specification for radio disturbance and immunity measuring apparatus and methods - Part 1-2: Radio disturbance and immunity measuring apparatus - Ancillary equipment - Conducted disturbances	EN 55016-1-2	2004 ¹⁾
+A1	2004		+A1	2005
+A2	2006		+A2	2006
CISPR 16-1-4	2010	Specification for radio disturbance and immunity measuring apparatus and methods - Part 1-4: Radio disturbance and immunity measuring apparatus - Antennas and test sites for radiated disturbance measurements	EN 55016-1-4	2010
+A1	2012		+A1	2012
CISPR 16-2-1	2008	Specification for radio disturbance and immunity measuring apparatus and methods - Part 2-1: Methods of measurement of disturbances and immunity - Conducted disturbance measurements	EN 55016-2-1	2009 ²⁾
+A1	2010		+A1	2011
+A2	2013		+A2	2013
CISPR 16-2-3	2010	Specification for radio disturbance and immunity measuring apparatus and methods - Part 2-3: Methods of measurement of disturbances and immunity - Radiated disturbance measurements	EN 55016-2-3	2010
+A1	2010		+AC	2013
+A2	2014		+A1	2010
			+A2	2014

¹⁾ Superseded by EN 55016-1-2:2014 (CISPR 16-1-2:2014): DOW = 2017-04-25.

²⁾ Superseded by EN 55016-2-1:2014 (CISPR 16-2-1:2014): DOW = 2017-04-02.

<u>Publication</u>	<u>Year</u>	<u>Title</u>	<u>EN/HD</u>	<u>Year</u>
CISPR 16-4-2	2011	Specification for radio disturbance and immunity measuring apparatus and methods - Part 4-2: Uncertainties, statistics and limit modelling - Measurement instrumentation uncertainty	EN 55016-4-2	2011
IEC 61000-4-6	2008	Electromagnetic compatibility (EMC) - Part 4-6: Testing and measurement techniques - Immunity to conducted disturbances, induced by radio-frequency fields	EN 61000-4-6	2009 ³⁾
ISO/IEC 17025	2005	General requirements for the competence - of testing and calibration laboratories	-	-
ANSI C63.5	2006	American National Standard (for) Electromagnetic Compatibility - Radiated Emission Measurements in Electromagnetic Interference (EMI) Control - Calibration of Antennas (9 kHz to 40 GHz)	-	-
IEEE 802.3	-	IEEE Standard for Information technology -- Specific requirements - Part 3: Carrier Sense Multiple Access with Collision Detection (CSMA/CD) Access Method and Physical Layer Specifications	-	-

³⁾ Superseded by EN 61000-4-6:2014 (IEC 61000-4-6:2013): DOW = 2016-11-27.

Annex ZZ
(informative)

Relationship between this European standard and the essential requirements of Directive 2014/30/EU [2014 OJ L96] aimed to be covered

This European standard has been prepared under the European Commission standardisation request C(2016) 7641 final of 30.11.2016¹, ('M/552'), as regards harmonised standards in support of Directive 2014/30/EU relating to electromagnetic compatibility, to provide one voluntary means of conforming to essential requirements of Directive 2014/30/EU of the European Parliament and of the Council of 26 February 2014 on the harmonisation of the laws of the Member States relating to electromagnetic compatibility [2014 OJ L96].

Once this standard is cited in the Official Journal of the European Union under that Directive, compliance with the normative clauses of this standard given in Table ZZ.1 confers, within the limits of the scope of this standard, a presumption of conformity with the corresponding essential requirements of that Directive, and associated EFTA regulations.

Table ZZ.1 — Correspondence between this European standard and the Essential Requirements set out in Directive 2014/30/EU [2014 OJ L96]

Essential requirements of Directive 2014/30/EU	Clause(s) / sub-clause(s) of this EN	Remarks / Notes
Annex I. 1(a) (electromagnetic disturbances)	5 Requirements	Not applicable to terrestrial and satellite broadcast receivers under Directive 2014/30/EU. With respect to Clause 11 (Measurement uncertainty), the following shall not be applied, if Clause 5 (Requirements) is applied for the purposes of the presumption of conformity: 'Refer to CISPR TR 16-4-3 for guidance on the applicability of the limits to a series production MME'.

WARNING 1: Presumption of conformity stays valid only as long as a reference to this European standard is maintained in the list published in the Official Journal of the European Union. Users of this standard should consult frequently the latest list published in the Official Journal of the European Union.

WARNING 2: Other Union legislation may be applicable to the product(s) falling within the scope of this standard."

¹ COMMISSION IMPLEMENTING DECISION C(2016) 7641 final of 30.11.2016 on a standardisation request to the European Committee for Standardisation, to the European Committee for Electrotechnical Standardisation and to the European Telecommunications Standards Institute as regards harmonised standards in support of Directive 2014/30/EU of the European Parliament and of the Council of 26 February 2014 on the harmonisation of the laws of the Member States relating to electromagnetic compatibility.

CONTENTS

FOREWORD	8
1 Scope	10
2 Normative references	10
3 Terms, definitions and abbreviations	11
3.1 Terms and definitions	11
3.2 Abbreviations	16
4 Classification of equipment	17
5 Requirements	18
6 Measurements	18
6.1 General	18
6.2 Host systems and modular EUT	18
6.3 Measurement procedure	19
7 Equipment documentation	20
8 Applicability	20
9 Test report	21
10 Compliance with this publication	22
11 Measurement uncertainty	22
Annex A (normative) Requirements	23
A.1 General	23
A.2 Requirements for radiated emissions	24
A.3 Requirements for conducted emissions	28
Annex B (normative) Exercising the EUT during measurement and test signal specifications	33
B.1 General	33
B.2 Exercising of EUT ports	33
B.2.1 Audio signals	33
B.2.2 Video signals	33
B.2.3 Digital broadcast signals	34
B.2.4 Other signals	34
Annex C (normative) Measurement procedures, instrumentation and supporting information	38
C.1 General	38
C.2 Instrumentation and supporting information	38
C.2.1 General	38
C.2.2 Using CISPR 16 series as the basic standard	38
C.2.3 EUT cycle time and measurement dwell time	41
C.3 General measurement procedures	41
C.3.1 Overview	41
C.3.2 Prescan measurements	43
C.3.3 Formal measurements	43
C.3.4 Specifics for radiated emission measurements	43
C.3.5 Specifics for conducted emission measurements on the AC mains power ports	43
C.3.6 Specifics for conducted emission measurements on analogue/digital data ports	43

C.3.7	Specifics for conducted emission measurements on broadcast receiver tuner ports	44
C.3.8	Specifics for conducted emission measurements on RF modulator output ports	44
C.4	MME-related measurement procedures	44
C.4.1	Measurement of conducted emissions at analogue/digital data ports	44
C.4.2	Measurement of emission voltages at a TV/FM broadcast receiver tuner ports in the frequency range 30 MHz to 2,15 GHz	50
C.4.3	Measurement of the wanted signal and emission voltage at RF modulator output ports, in the frequency range 30 MHz to 2,15 GHz	51
C.4.4	Additional Normalized Site Attenuation (NSA) values	52
Annex D (normative)	Arrangement of EUT, local AE and associated cabling	54
D.1	Overview	54
D.1.1	General	54
D.1.2	Table-top arrangement	58
D.1.3	Floor standing arrangement	58
D.1.4	Combinations of table-top and floor standing EUT arrangement	59
D.1.5	Arrangements for radiated measurement in a FAR	59
D.2	MME-related conditions for conducted emission measurement	59
D.2.1	General	59
D.2.2	Specific conditions for table-top equipment	60
D.2.3	Specific requirements for floor standing equipment	61
D.2.4	Specific requirements for combined table-top and floor standing equipment	61
D.3	MME-related requirements for radiated measurement	61
D.3.1	General	61
D.3.2	Requirements for table-top equipment	61
Annex E (informative)	Prescan measurements	72
Annex F (informative)	Test report contents summary	73
Annex G (informative)	Support information for the measurement procedures defined in C.4.1.1	74
G.1	Schematic diagrams of examples of asymmetric artificial networks	74
G.2	Rationale for emission measurements and procedures for wired network ports	83
G.2.1	Limits	83
G.2.2	Combination of current probe and CVP	84
G.2.3	Basic ideas of the CVP	85
G.2.4	Combination of current and voltage limit	85
G.2.5	Ferrite requirements for use in C.4.1.1	87
Annex H (normative)	Supporting information for the measurement of outdoor unit of home satellite receiving systems	90
H.1	Rationale	90
H.2	General	90
H.3	Operation conditions	91
H.4	Specific requirements for LO measurement	91
H.5	EUT arrangements	92
Annex I (informative)	Other test methods and associated limits for radiated emissions	94
I.1	General	94
I.2	Procedures for radiated emission measurements using a GTEM or RVC	94
I.3	Additional measurement procedure information	96

1.3.1	General	96
1.3.2	Specific considerations for radiated emission measurements using a GTEM	96
1.3.3	Specific considerations for radiated emission measurements using an RVC	96
1.4	Use of a GTEM for radiated emission measurements	97
1.4.1	General	97
1.4.2	EUT layout	97
1.4.3	GTEM, measurements above 1 GHz	98
1.4.4	Uncertainties	99
1.5	Specific EUT arrangement requirements for radiated emission measurements above 1 GHz using an RVC	99
1.6	Reference documents	99
	Bibliography	101
	Figure 1 – Examples of ports	15
	Figure 2 – Example of a host system with different types of modules	19
	Figure A.1 – Graphical representation of the limits for the AC mains power port defined in Table A.10	23
	Figure C.1 – Measurement distance	39
	Figure C.2 – Boundary of EUT, Local AE and associated cabling	40
	Figure C.3 – Decision tree for using different detectors with quasi peak and average limits	41
	Figure C.4 – Decision tree for using different detectors with peak and average limits	42
	Figure C.5 – Decision tree for using different detectors with a quasi-peak limit	42
	Figure C.6 – Calibration fixture	50
	Figure C.7 – Arrangement for measuring impedance in accordance with C.4.1.7	50
	Figure C.8 – Circuit arrangement for measurement of emission voltages at TV/FM broadcast receiver tuner ports	51
	Figure C.9 – Circuit arrangement for the measurement of the wanted signal and emission voltage at the RF modulator output port of an EUT	52
	Figure D.1 – Example measurement arrangement for table-top EUT (conducted and radiated emission) (top view)	62
	Figure D.2 – Example measurement arrangement for table-top EUT (conducted emission measurement – alternative 1)	63
	Figure D.3 – Example measurement arrangement for table-top EUT (conducted emission measurement – alternative 2)	64
	Figure D.4 – Example measurement arrangement for table-top EUT measuring in accordance with C.4.1.6.4	64
	Figure D.5 – Example measurement arrangement for table-top EUT (conducted emission measurement – alternative 2, showing AAN position)	65
	Figure D.6 – Example measurement arrangement for floor standing EUT (conducted emission measurement)	66
	Figure D.7 – Example measurement arrangement for combinations of EUT (conducted emission measurement)	67
	Figure D.8 – Example measurement arrangement for table-top EUT (radiated emission measurement)	67
	Figure D.9 – Example measurement arrangement for floor standing EUT (radiated emission measurement)	68

Figure D.10 – Example measurement arrangement for combinations of EUT (radiated emission measurement)	69
Figure D.11 – Example measurement arrangement for tabletop EUT (radiated emission measurement within a FAR)	70
Figure D.12 – Example cable configuration and EUT height (radiated emission measurement within a FAR)	71
Figure G.1 – Example AAN for use with unscreened single balanced pairs	74
Figure G.2 – Example AAN with high LCL for use with either one or two unscreened balanced pairs	75
Figure G.3 – Example AAN with high LCL for use with one, two, three, or four unscreened balanced pairs	76
Figure G.4 – Example AAN, including a 50 Ω source matching network at the voltage measuring port, for use with two unscreened balanced pairs	77
Figure G.5 – Example AAN for use with two unscreened balanced pairs	78
Figure G.6 – Example AAN, including a 50 Ω source matching network at the voltage measuring port, for use with four unscreened balanced pairs	79
Figure G.7 – Example AAN for use with four unscreened balanced pairs	80
Figure G.8 – Example AAN for use with coaxial cables, employing an internal common mode choke created by bifilar winding an insulated centre-conductor wire and an insulated screen-conductor wire on a common magnetic core (for example, a ferrite toroid)	81
Figure G.9 – Example AAN for use with coaxial cables, employing an internal common mode choke created by miniature coaxial cable (miniature semi-rigid solid copper screen or miniature double-braided screen coaxial cable) wound on ferrite toroids	81
Figure G.10 – Example AAN for use with multi-conductor screened cables, employing an internal common mode choke created by multifilar winding multiple insulated signal wires and an insulated screen-conductor wire on a common magnetic core (for example, a ferrite toroid)	82
Figure G.11 – Example AAN for use with multi-conductor screened cables, employing an internal common mode choke created by winding a multi-conductor screened cable on ferrite toroids	83
Figure G.12 – Basic circuit for considering the limits with defined common mode impedance of 150 Ω	86
Figure G.13 – Basic circuit for the measurement with unknown common mode impedance	86
Figure G.14 – Impedance layout of the components in the method described in C.4.1.6.3	87
Figure G.15 – Basic measurement setup to measure combined impedance of the 150 Ω and ferrites	89
Figure H.1 – Description of $\pm 7^\circ$ of the main beam axis of the EUT	92
Figure H.2 – Example measurement arrangements of transmit antenna for the wanted signal	93
Figure I.1 – Typical GTEM side sectional view showing some basic parts	97
Figure I.2 – Typical GTEM plan sectional view showing floor layout	98
Figure I.3 – Typical EUT mounting for combination of modules being measured	98
Figure I.4 – Overview of the reverberation chamber for radiated emission measurement	99
Table 1 – Required highest frequency for radiated measurement	21

Table A.1 – Radiated emissions, basic standards and the limitation of the use of particular methods	25
Table A.2 – Requirements for radiated emissions at frequencies up to 1 GHz for class A equipment	26
Table A.3 – Requirements for radiated emissions at frequencies above 1 GHz for class A equipment	26
Table A.4 – Requirements for radiated emissions at frequencies up to 1 GHz for class B equipment	26
Table A.5 – Requirements for radiated emissions at frequencies above 1 GHz for class B equipment	27
Table A.6 – Requirements for radiated emissions from FM receivers	27
Table A.7 – Requirements for outdoor units of home satellite receiving systems	28
Table A.8 – Conducted emissions, basic standards and the limitation of the use of particular methods	29
Table A.9 – Requirements for conducted emissions from the AC mains power ports of Class A equipment.....	29
Table A.10 – Requirements for conducted emissions from the AC mains power ports of Class B equipment.....	30
Table A.11 – Requirements for asymmetric mode conducted emissions from Class A equipment.....	30
Table A.12 – Requirements for asymmetric mode conducted emissions from Class B equipment.....	31
Table A.13 – Requirements for conducted differential voltage emissions from Class B equipment.....	32
Table B.1 – Methods of exercising displays and video ports.....	34
Table B.2 – Display and video parameters	34
Table B.3 – Methods used to exercise ports.....	35
Table B.4 – Examples of digital broadcast signal specifications	36
Table C.1 – Analogue/digital data port emission procedure selection	45
Table C.2 – LCL values.....	46
Table C.3 – 5 m OATS/SAC NSA values	53
Table D.1 – Measurement arrangements of EUT	54
Table D.2 – Arrangement spacing, distances and tolerances	57
Table F.1 – Summary of information to include in a test report.....	73
Table G.1 – Summary of advantages and disadvantages of the procedures described in C.4.1.6.....	84
Table H.1 – Derivation of the limit within $\pm 7^\circ$ of the main beam axis.....	90
Table I.1 – Radiated emissions, basic standards and the limitation of the use of GTEM and RVC methods.....	94
Table I.2 – Proposed limits for radiated emissions at frequencies up to 1 GHz for Class A equipment, for GTEM.....	95
Table I.3 – Proposed limits for radiated emission for frequencies above 1 GHz for Class A equipment, for GTEM.....	95
Table I.4 – Proposed limits for radiated emission for frequencies above 1 GHz for Class A equipment, for RVC	95
Table I.5 – Proposed limits for radiated emissions at frequencies up to 1 GHz for Class B equipment, for GTEM.....	96
Table I.6 – Proposed limits for radiated emission for frequencies above 1 GHz for Class B equipment, for GTEM.....	96

Table I.7 – Proposed limits for radiated emission for frequencies above 1 GHz for
Class B equipment, for RVC 96

INTERNATIONAL ELECTROTECHNICAL COMMISSION

**ELECTROMAGNETIC COMPATIBILITY
OF MULTIMEDIA EQUIPMENT –****Emission requirements**

FOREWORD

- 1) The International Electrotechnical Commission (IEC) is a worldwide organization for standardization comprising all national electrotechnical committees (IEC National Committees). The object of IEC is to promote international co-operation on all questions concerning standardization in the electrical and electronic fields. To this end and in addition to other activities, IEC publishes International Standards, Technical Specifications, Technical Reports, Publicly Available Specifications (PAS) and Guides (hereafter referred to as “IEC Publication(s)”). Their preparation is entrusted to technical committees; any IEC National Committee interested in the subject dealt with may participate in this preparatory work. International, governmental and non-governmental organizations liaising with the IEC also participate in this preparation. IEC collaborates closely with the International Organization for Standardization (ISO) in accordance with conditions determined by agreement between the two organizations.
- 2) The formal decisions or agreements of IEC on technical matters express, as nearly as possible, an international consensus of opinion on the relevant subjects since each technical committee has representation from all interested IEC National Committees.
- 3) IEC Publications have the form of recommendations for international use and are accepted by IEC National Committees in that sense. While all reasonable efforts are made to ensure that the technical content of IEC Publications is accurate, IEC cannot be held responsible for the way in which they are used or for any misinterpretation by any end user.
- 4) In order to promote international uniformity, IEC National Committees undertake to apply IEC Publications transparently to the maximum extent possible in their national and regional publications. Any divergence between any IEC Publication and the corresponding national or regional publication shall be clearly indicated in the latter.
- 5) IEC itself does not provide any attestation of conformity. Independent certification bodies provide conformity assessment services and, in some areas, access to IEC marks of conformity. IEC is not responsible for any services carried out by independent certification bodies.
- 6) All users should ensure that they have the latest edition of this publication.
- 7) No liability shall attach to IEC or its directors, employees, servants or agents including individual experts and members of its technical committees and IEC National Committees for any personal injury, property damage or other damage of any nature whatsoever, whether direct or indirect, or for costs (including legal fees) and expenses arising out of the publication, use of, or reliance upon, this IEC Publication or any other IEC Publications.
- 8) Attention is drawn to the Normative references cited in this publication. Use of the referenced publications is indispensable for the correct application of this publication.
- 9) Attention is drawn to the possibility that some of the elements of this IEC Publication may be the subject of patent rights. IEC shall not be held responsible for identifying any or all such patent rights.

International Standard CISPR 32 has been prepared by CISPR subcommittee 1: Electromagnetic compatibility of information technology equipment, multimedia equipment and receivers.

This second edition cancels and replaces the first edition published in 2012. This edition constitutes a technical revision.

This edition includes the following significant technical changes with respect to the previous edition:

- a) additional requirements using FAR,
- b) additional requirements for outdoor unit of home satellite receiving systems,
- c) addition of new informative annexes covering GTEM and RVC,
- d) numerous maintenance items are addressed to improve the testing of MME.

The text of this publication is based on the following documents:

FDIS	Report on voting
CIS/1/498/FDIS	CIS/1/501/RVD

Full information on the voting for the approval of this publication can be found in the report on voting indicated in the above table.

This publication has been drafted in accordance with the ISO IEC Directives, Part 2.

The committee has decided that the contents of this publication will remain unchanged until the stability date indicated on the IEC website under "<http://webstore.iec.ch>" in the data related to the specific publication. At this date, the publication will be

- reconfirmed,
- withdrawn,
- replaced by a revised edition, or
- amended.

IMPORTANT – The 'colour inside' logo on the cover page of this publication indicates that it contains colours which are considered to be useful for the correct understanding of its contents. Users should therefore print this document using a colour printer.

The contents of the corrigendum of June 2016 have been included in this copy.

ELECTROMAGNETIC COMPATIBILITY OF MULTIMEDIA EQUIPMENT –

Emission requirements

1 Scope

NOTE Blue coloured text within this document indicates text that will be aligned with the future MME immunity publication CISPR 35.

This International Standard applies to multimedia equipment (MME) as defined in 3.1.24 and having a rated r.m.s. AC or DC supply voltage not exceeding 600 V.

Equipment within the scope of CISPR 13 or CISPR 22 is within the scope of this publication.

MME intended primarily for professional use is within the scope of this publication.

The radiated emission requirements in this standard are not intended to be applicable to the intentional transmissions from a radio transmitter as defined by the ITU, nor to any spurious emissions related to these intentional transmissions.

Equipment, for which emission requirements in the frequency range covered by this publication are explicitly formulated in other CISPR publications (except CISPR 13 and CISPR 22), are excluded from the scope of this publication.

In-situ testing is outside the scope of this publication.

This publication covers two classes of MME (Class A and Class B). The MME classes are specified in Clause 4.

The objectives of this publication are:

- 1) to establish requirements which provide an adequate level of protection of the radio spectrum, allowing radio services to operate as intended in the frequency range 9 kHz to 400 GHz;
- 2) to specify procedures to ensure the reproducibility of measurement and the repeatability of results.

2 Normative references

The following documents, in whole or in part, are normatively referenced in this document and are indispensable for its application. For dated references, only the edition cited applies. For undated references, the latest edition of the referenced document (including any amendments) applies.

CISPR 16-1-1:2010, *Specification for radio disturbance and immunity measuring apparatus and methods – Part 1-1: Radio disturbance and immunity measuring apparatus – Measuring apparatus*

CISPR 16-1-1:2010/AMD1:2010

CISPR 16-1-1:2010/AMD2:2014

CISPR 16-1-2:2003¹, *Specification for radio disturbance and immunity measuring apparatus and methods – Part 1-2: Radio disturbance and immunity measuring apparatus – Ancillary equipment – Conducted disturbances*

CISPR 16-1-2:2003/AMD 1:2004

CISPR 16-1-2:2003/AMD 2:2006

CISPR 16-1-4:2010, *Specification for radio disturbance and immunity measuring apparatus and methods – Part 1-4: Radio disturbance and immunity measuring apparatus – Antennas and test sites for radiated disturbance measurements*

CISPR 16-1-4:2010/AMD1:2012

CISPR 16-2-1:2008², *Specification for radio disturbance and immunity measuring apparatus and methods – Part 2-1: Methods of measurement of disturbances and immunity – Conducted disturbance measurements*

CISPR 16-2-1:2008/ AMD 1:2010

CISPR 16-2-1:2008/ AMD 2:2013

CISPR 16-2-3:2010, *Specification for radio disturbance and immunity measuring apparatus and methods – Part 2-3: Methods of measurement of disturbances and immunity – Radiated disturbance measurements*

CISPR 16-2-3:2010/AMD1:2010

CISPR 16-2-3:2010/AMD2:2014

CISPR 16-4-2:2011, *Specification for radio disturbance and immunity measuring apparatus and methods – Part 4-2: Uncertainties, statistics and limit modelling – Measurement instrumentation uncertainty*

IEC 61000-4-6:2008³, *Electromagnetic compatibility (EMC) – Part 4-6: Testing and measurement techniques – Immunity to conducted disturbances, induced by radio-frequency fields*

ISO IEC 17025:2005, *General requirements for the competence of testing and calibration laboratories*

ANSI C63.5-2006, *American National Standard (for) Electromagnetic Compatibility – Radiated Emission Measurements in Electromagnetic Interference (EMI) Control – Calibration of Antennas (9 kHz to 40 GHz)*

IEEE Std 802.3, *IEEE Standard for Information technology – Specific requirements – Part 3: Carrier Sense Multiple Access with Collision Detection (CSMA/CD) Access Method and Physical Layer Specifications*

3 Terms, definitions and abbreviations

3.1 Terms and definitions

For the purposes of this document, the following terms and definitions apply.

¹ First edition (2003). This first edition has been replaced in 2014 by a second edition CISPR 16-1-2:2014, *Specification for radio disturbance and immunity measuring apparatus and methods – Part 1-2: Radio disturbance and immunity measuring apparatus – Coupling devices for conducted disturbance measurements*.

² First edition (2008). This first edition has been replaced in 2014 by a second edition CISPR 16-2-1:2014, *Specification for radio disturbance and immunity measuring apparatus and methods – Part 2-1: Methods of measurement of disturbances and immunity – Conducted disturbance measurements*.

³ Third edition (2008). This third edition has been replaced in 2013 by a fourth edition IEC 61000-4-6:2013, *Electromagnetic compatibility (EMC) – Part 4-6: Testing and measurement techniques – Immunity to conducted disturbances, induced by radio-frequency fields*.

NOTE Terms and definitions related to EMC and to relevant phenomena are given in IEC 60050-161. A common set of definitions has been written for both CISPR 32 and the future CISPR 35. It is noted that some terms and definitions will only be used in one of these two publications but for purposes of consistency they are intentionally included in both.

3.1.1

AC mains power port

port used to connect to the mains supply network

Note 1 to entry: Equipment with a DC power port which is powered by a dedicated AC/DC power converter is defined as AC mains powered equipment.

3.1.2

analogue/digital data port

signal/control port (3.1.30), antenna port (3.1.3), wired network port (3.1.32), broadcast receiver tuner port (3.1.8), or optical fibre port (3.1.25) with metallic shielding and/or metallic strain relief member(s)

3.1.3

antenna port

port, other than a broadcast receiver tuner port (3.1.8), for connection of an antenna used for intentional transmission and/or reception of radiated RF energy

3.1.4

arrangement

physical layout and orientation of all the parts of the EUT, AE and any associated cabling, located within the area

3.1.5

associated equipment

AE

equipment needed to exercise and/or monitor the operation of the EUT

Note 1 to entry: AE may be either local (within the measurement or test area) or remote.

3.1.6

audio equipment

equipment which has a primary function of either (or a combination of) generation, input, storage, play, retrieval, transmission, reception, amplification, processing, switching or control of audio signals

3.1.7

broadcast receiver equipment

equipment containing a tuner that is intended for the reception of broadcast services

Note 1 to entry: These broadcast services are typically television and radio services, including terrestrial broadcast, satellite broadcast and/or cable transmission.

3.1.8

broadcast receiver tuner port

port intended for the reception of a modulated RF signal carrying terrestrial, satellite and/or cable transmissions of audio and/or video broadcast and similar services

Note 1 to entry: This port may be connected to an antenna, a cable distribution system, a VCR or similar device.

3.1.9

common mode impedance

asymmetrical mode (see CISPR 16-2-1) impedance between a cable attached to a port and the Reference Ground Plane (RGP)

Note 1 to entry: The complete cable is seen as one wire of the circuit and the RGP is seen as the other wire of the circuit. The common mode current flowing around this circuit can lead to the emission of radiated energy of EUT.

3.1.10 configuration

operational conditions of the EUT and AE, consisting of the set of hardware elements selected to comprise the EUT and AE, mode of operation (3.1.23) used to exercise the EUT and arrangement (3.1.4) of the EUT and AE

3.1.11 converted common mode current

asymmetrical mode current converted from differential mode current by the unbalance of an attached cable and/or network

3.1.12 DC network power port

port, not powered by a dedicated AC/DC power converter and not supporting communication, that connects to a DC supply network

Note 1 to entry: Equipment with a DC power port which is powered by a dedicated AC/DC power converter is considered to be AC mains powered equipment.

Note 2 to entry: DC power ports supporting communications are considered to be wired networks ports, for example Ethernet ports which include Power Over Ethernet (POE).

3.1.13 enclosure port

physical boundary of the EUT through which electromagnetic fields may radiate

3.1.14 entertainment lighting control equipment

equipment generating or processing electrical signals for controlling the intensity, colour, nature or direction of the light from a luminaire, where the intention is to create artistic effects in theatrical, televisual or musical productions and visual presentations

3.1.15 Equipment Under Test EUT

multimedia equipment (MME) being evaluated for compliance with the requirements of this standard

3.1.16 formal measurement

measurement used to determine compliance

Note 1 to entry: This is often the final measurement performed. It may be carried out following a prescan measurement. It is the measurement recorded in the test report.

3.1.17 function

operation carried out by a MME

Note 1 to entry: Functions are related to basic technologies incorporated in the MME such as: displaying, recording, processing, controlling, reproducing, transmitting, or receiving single medium or multimedia content. The content may be data, audio or video, either individually or in combination.

3.1.18 highest internal frequency

F_x

highest fundamental frequency generated or used within the EUT or highest frequency at which it operates

Note 1 to entry: This includes frequencies which are solely used within an integrated circuit.

3.1.19
Information Technology Equipment
ITE

equipment having a primary function of either (or a combination of) entry, storage, display, retrieval, transmission, processing, switching, or control of data and/or telecommunication messages and which may be equipped with one or more ports typically for information transfer

Note 1 to entry: Examples include data processing equipment, office machines, electronic business equipment and telecommunication equipment.

3.1.20
LNB

low noise block convertor which amplifies and converts broadcast satellite frequencies to frequencies usable by a satellite receiver

3.1.21
local AE

AE located within the measurement or test area

3.1.22
launched common mode current

asymmetric mode current produced by internal circuitry and appearing at the wired network port of the EUT

Note 1 to entry: Measurement of the launched common mode current requires the EUT port to be loaded by a perfectly balanced termination.

3.1.23
mode of operation

set of operational states of all functions of an EUT during a test or measurement

3.1.24
MultiMedia Equipment
MME

equipment that is information technology equipment (3.1.19), audio equipment (3.1.6), video equipment (3.1.31), broadcast receiver equipment (3.1.7), entertainment lighting control equipment (3.1.14) or combinations of these

3.1.25
optical fibre port

port at which an optical fibre is connected to an equipment

3.1.26
outdoor unit of home satellite receiving systems

outdoor unit which typically consists of a reflecting surface (or antenna) and an LNB

Note 1 to entry: The unit excludes the intermediate frequency amplifier and the demodulator included in the indoor receiver.

3.1.27
port

physical interface through which electromagnetic energy enters or leaves the EUT

Note 1 to entry: See Figure 1.

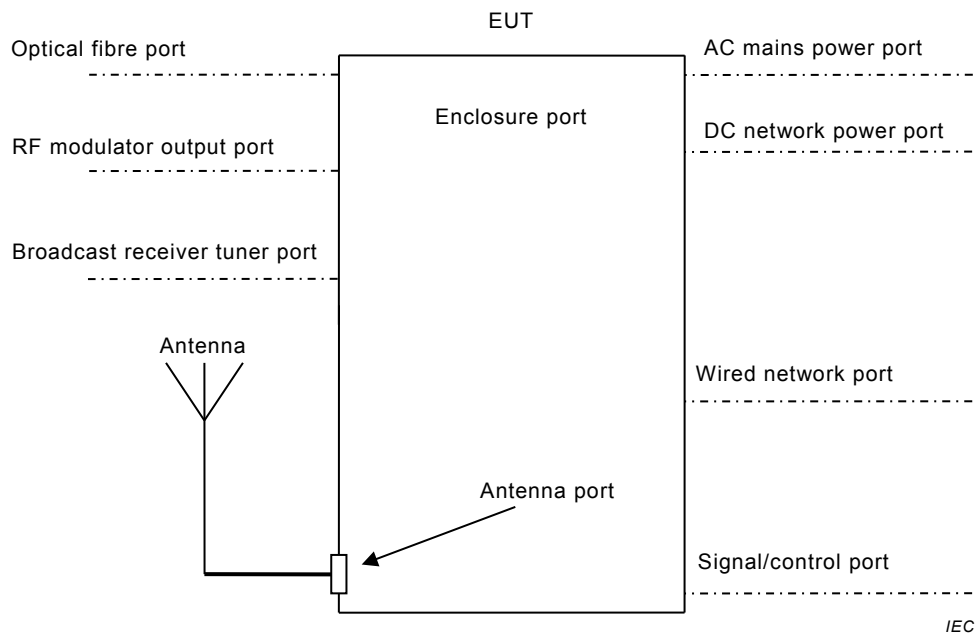

Figure 1 – Examples of ports

3.1.28 primary function

any function of an MME considered essential for the user or for the majority of users

Note 1 to entry: An MME may have more than one primary function. For example the primary functions of a basic television set include broadcast reception, audio reproduction and display.

3.1.29 RF modulator output port

port intended to be connected to a broadcast receiver tuner port in order to transmit a signal to the broadcast receiver

3.1.30 signal/control port

port intended for the interconnection of components of an EUT, or between an EUT and local AE and used in accordance with relevant functional specifications (for example for the maximum length of cable connected to it)

Note 1 to entry: Examples include RS-232, Universal Serial Bus (USB), High-Definition Multimedia Interface (HDMI), IEEE Standard 1394 ("Fire Wire").

3.1.31 video equipment

equipment which has a primary function of either (or a combination of) generation, input, storage, display, play, retrieval, transmission, reception, amplification, processing, switching, or control of video signals

3.1.32 wired network port

port for the connection of voice, data and signalling transfers intended to interconnect widely-dispersed systems by direct connection to a single-user or multi-user communication network

Note 1 to entry: Examples of these include CATV, PSTN, ISDN, xDSL, LAN and similar networks.

Note 2 to entry: These ports may support screened or unshielded cables and may also carry AC or DC power where this is an integral part of the telecommunication specification.

3.2 Abbreviations

For the purposes of this document, the following abbreviations apply.

AAN	Asymmetric Artificial Network
AC	Alternating Current
AC-3	ATSC standard: digital Audio Compression (AC-3)
AE	Associated Equipment, see 3.1.5
AM	Amplitude Modulation
AMN	Artificial Mains Network
ATSC	Advanced Television Systems Committee
AV	Audio Visual
BPSK	Binary Phase Shift Keying
CATV	Cable TV network
CISPR	International special committee on radio interference
CM	Common Mode
CMAD	Common Mode Absorbing Device
CVP	Capacitive Voltage Probe
DC	Direct Current
DMB-T	Digital Multimedia Broadcast – Terrestrial
DQPSK	Differential Quadrature Phase Shift Keying
DSL	Digital Subscriber Line
DVB	Digital Video Broadcast
DVB-C	Digital Video Broadcast – Cable
DVB-S	Digital Video Broadcast – Satellite
DVB-T	Digital Video Broadcast – Terrestrial
DVD	Digital Versatile Disc (an optical disc format also known as a Digital Video Disc)
EMC	ElectroMagnetic Compatibility
EUT	Equipment Under Test, see 3.1.15
FAR	Fully Anechoic Room
FM	Frequency Modulation
FSOATS	Free Space Open Area Test Site
F/UTP	Foil screened/Unscreened Twisted Pair
GTEM	Gigahertz Transverse ElectroMagnetic
HDMI	High-Definition Multimedia Interface
HID	Human Interface Device
IEC	International Electrotechnical Commission
IF	Intermediate Frequency
ISDB	Integrated Services Digital Broadcasting
ISDB-S	Integrated Services Digital Broadcasting – Satellite
ISDN	Integrated Services Digital Network
ISO	International Standardisation Organisation
ITE	Information Technology Equipment, see 3.1.19
ITU	International Telecommunication Union

ITU-R	International Telecommunication Union – Radio Communication Sector
ITU-T	International Telecommunication Union – Telecommunication Sector
LAN	Local Area Network
LCL	Longitudinal Conversion Loss
LO	Local Oscillator
LNB	Low-Noise Block converter
MME	Multimedia Equipment, see 3.1.24
MPEG	Moving Picture Experts Group
NSA	Normalized Site Attenuation
OATS	Open Area Test Site
OFDM	Orthogonal Frequency Division Multiplexing
PC	Personal Computer
POE	Power Over Ethernet
POS	Point Of Sale
PSTN	Public Switched Telephone Network
PSU	Power Supply Unit (including a AC/DC power converter)
QAM	Quadrature Amplitude Modulation
QPSK	Quadrature Phase Shift Keying
RF	Radio Frequency
RGP	Reference Ground Plane
RVC	ReVerberation Chamber
SAC	Semi Anechoic Chamber
STP	Shielded Twisted Pair
TV	Television
TEM	Transverse ElectroMagnetic
UHF	Ultra High Frequency
USB	Universal Serial Bus
U/UTP	Unscreened/Unscreened Twisted Pair
VCR	Video Cassette Recorder
VHF	Very High Frequency
VSF	Vestigial Side Band
xBase-T	Where x is 10, 100 and 1 000 as defined in the IEEE 802.3 series of standards
xDSL	Generic term for all types of DSL technology

4 Classification of equipment

This standard defines Class A equipment and Class B equipment associated with two types of end-use environment.

Class A equipment is equipment which meets the requirements given in Table A.2, Table A.3, Table A.9, and Table A.11, using the limitations defined in Table A.1 and Table A.8.

Class B equipment is equipment which meets the requirements given in Table A.4, Table A.5, Table A.6, Table A.7, Table A.10, Table A.12 and Table A.13, using the limitations defined in Table A.1 and Table A.8.

The Class B requirements for equipment are intended to offer adequate protection to broadcast services within the residential environment.

Equipment intended primarily for use in a residential environment shall meet the Class B limits. All other equipment shall comply with the Class A limits.

Broadcast receiver equipment is class B equipment.

NOTE Equipment meeting Class A requirements may not offer adequate protection to broadcast services within a residential environment.

5 Requirements

The requirements for equipment covered within the scope of this publication are defined in Annex A.

6 Measurements

6.1 General

This clause defines the measurement facilities and instrumentation specific to the measurement of emissions from MME; it includes by reference the relevant basic requirements given in the CISPR 16 series and other standards shown in the normative references in this standard. It also defines how to configure and arrange the EUT, local AE and associated cabling, and provides the relevant measurement procedures.

The specification of the measurement facility, measurement equipment, procedures, and the arrangement of the measurement equipment to be used are given in the basic standards referred to in the tables in Annex A. Unless otherwise specified, the basic standards shall be used for all aspects of the measurement.

Where there are conflicts in the information presented in the CISPR 16 series and this publication, the content of this publication takes precedence.

The procedures to be used for measurement of emission levels depend upon several elements. These include but are not limited to:

- the type of EUT,
- the type of port,
- the types of cables used,
- the frequency range,
- the mode of operation.

If a single port satisfies the definition of more than one of the types of port defined in this standard, it is subject to the requirements for each of the port types that it satisfies. Where a port is specified by the manufacturer for use with both screened and unscreened cables, the port shall be evaluated with both cable types.

6.2 Host systems and modular EUT

This subclause describes how to configure EUTs that are a host system or modular in nature. Modular systems can comprise different types of module(s), for example the EUT can be:

- an external module, for example an infra-red remote control;
- an internal module, for example a computer hard disk;
- a plug-in module, for example a memory stick;

- a mounted module, for example a sound card or a video card.

Modules intended to be marketed and/or sold separately from a host shall be assessed with at least one representative host system. The modules may be internal, mounted, plug-in or external as illustrated in Figure 2. The port(s) of any module being assessed shall be terminated in accordance with Annex D. The functions of the host device that are specific to the module being assessed shall be exercised during the measurements. Modules shown to meet the requirements of this publication in any one representative host are deemed to meet the requirements of this publication when used in any host. The host and modules used during measurements shall be listed in the test report.

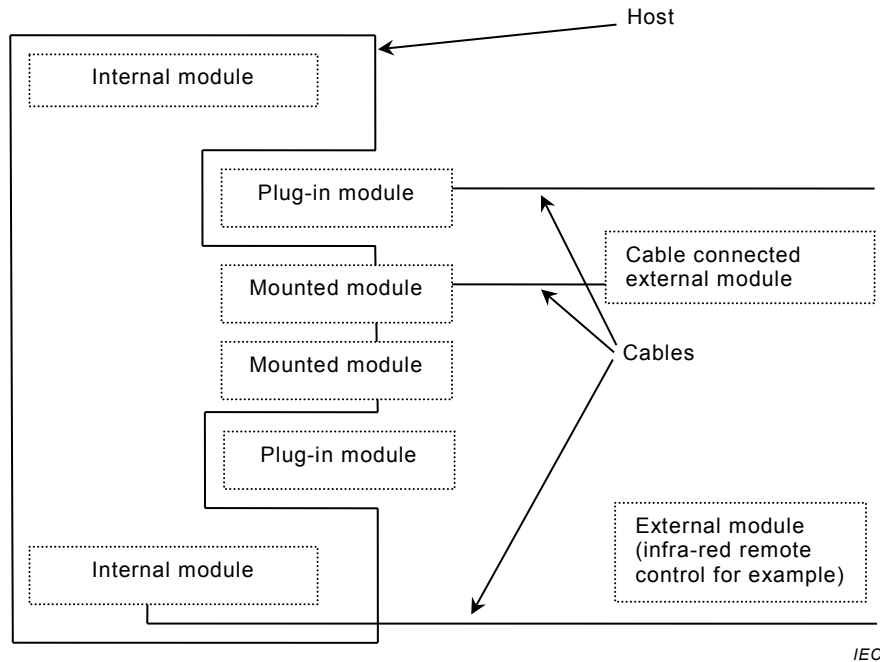

Figure 2 – Example of a host system with different types of modules

Modules whose functionality and connectivity allow them to be either, plug-in, internal, mounted and/or external shall be measured in each of the applicable configurations. However, where it can be shown that one particular configuration provides a worst case, measurement in the worst case configuration is sufficient to show compliance.

When the EUT is a host, it shall be configured with modules so that the resulting system is representative of typical use.

In the case where the EUT is a module, the host is considered as an AE.

In the case of plug-in, mounted, external or internal modules, the host shall be located in the measurement area.

6.3 Measurement procedure

Measurements shall be performed as follows:

- using the relevant measurement methods and procedures given in Table A.1, Table A.8 and Annex C, and the EUT exercised in accordance with Annex B;
- with the EUT, local AE and associated cabling configured and arranged, and with ports loaded as shown in 6.2 and Annex D;
- in accordance with supporting information and clarifications defined elsewhere within this publication.

In addition, during prescan measurements, the arrangement of the EUT, the arrangement of the local AE and the placement of cables shall be varied within the range of typical and normal placement to attempt to determine the cable arrangement giving the maximum emission level, as described in Annex D.

The arrangement for formal measurement shall be representative of a typical arrangement of the EUT, local AE and associated cabling.

The measurement is performed with the EUT and/or AE arranged either as floor-standing equipment, table-top equipment or combinations thereof as defined in D.1.1 and illustrated in Figure D.2 to Figure D.12.

For some products it is not always obvious how the EUT and/or AE should be arranged. This may be due to variations in the configurations of the EUT in practice, physical or practical limitations. Examples of these arrangements include:

- wall, ceiling or rack mounted,
- handheld,
- body worn.

For example, a video projector can be positioned in various ways with respect to walls, ceiling or the floor of a room. D.1.1 defines the additional information needed to configure the EUT to simulate these types of arrangements.

7 Equipment documentation

The user documentation and/or manual shall contain details of any special measures required to be taken by the purchaser or user to ensure EMC compliance of the EUT with the requirements of this publication. One example would be the need to use shielded or special cables, such as category 5 F/UTP or category 6 U/UTP cabling as defined in ISO IEC 11801.

Equipment compliant with the class A requirements of this publication should have a warning notice in the user manual stating that it could cause radio interference. For example

Warning: Operation of this equipment in a residential environment could cause radio interference.

8 Applicability

Measurements shall be performed on the relevant ports of the EUT according to the appropriate tables given in Annex A.

Where a manufacturer determines from the electrical characteristics and intended usage of the EUT that one or more measurements are unnecessary, the decision and justification not to perform these measurements shall be recorded in the test report.

The following table shows the highest frequency up to which radiated emission measurements shall be performed.

Based upon the value of F_x , Table 1 specifies the highest frequency applicable for the limits given in Table A.3 or Table A.5.

Table 1 – Required highest frequency for radiated measurement

Highest internal frequency (F_x)	Highest measured frequency
$F_x \leq 108$ MHz	1 GHz
$108 \text{ MHz} < F_x \leq 500$ MHz	2 GHz
$500 \text{ MHz} < F_x \leq 1$ GHz	5 GHz
$F_x > 1$ GHz	$5 \times F_x$ up to a maximum of 6 GHz

NOTE 1 For FM and TV broadcast receivers, F_x is determined from the highest frequency generated or used excluding the local oscillator and tuned frequencies.

NOTE 2 F_x is defined in 3.1.18.

NOTE 3 For outdoor units of home satellite receiving systems highest measured frequency shall be 18 GHz.

Where F_x is unknown, the radiated emission measurements shall be performed up to 6 GHz.

9 Test report

General requirements for compiling a test report taken from 5.10 of ISO IEC 17025:2005, can be found in Annex F. Sufficient details shall be provided to facilitate reproducibility of the measurements. This shall include photographs of the measurement configuration for the formal measurements where this is appropriate.

The test report shall state the mode of operation of the EUT and how its ports were exercised (see Annex B). The test report shall clearly indicate whether the product is compliant with the Class A or Class B limits defined in Annex A.

For each relevant table clause in Annex A, the test report shall include the measurement results of at least the six highest emissions relative to the limit for each detector type,⁴ unless the emissions are:

- below the measurement system noise floor, or
- 10 dB or more below the limit.

The results shall include the following information for each of these emissions:

- the port assessed (including enough information to identify it);
- for AC power line measurements the line under test, for example line or neutral;
- frequency and amplitude of the emission;
- margin with respect to the specified limit;
- the limit at the frequency of the emission;
- the detector used.

The report shall indicate if fewer than six emissions within 10 dB of the limit are observed.

NOTE It can also be beneficial to record emissions 10 dB or more below the limit. In addition other aspects, such as antenna polarization or turntable azimuth, can be useful to record.

Additionally, the following shall be included in the test report:

⁴ It is sufficient to show compliance with all limits and detectors as shown in Figure C.3 to Figure C.5.

- the frequency F_x of the highest internal frequency source within the EUT as defined in 3.1.18. This frequency need not be reported if radiated emissions are measured up to 6 GHz;
- the calculated measurement instrumentation uncertainty for each measurement type performed (see Table 1 of CISPR 16-4-2:2011). No reporting is required if U_{CISPR} is not defined for the relevant measurement type;
- the category of cable simulated by the AAN, where emissions from wired network ports are measured using an AAN. See Table C.2;
- the measurement distance for radiated emission measurements as defined in C.2.2.4 and Table A.2 to Table A.7. If another measurement distance is used, the report shall include a description of how the limits were calculated.

Further guidance is given in Annex F.

10 Compliance with this publication

Compliance with this publication requires that the EUT satisfies either the Class A or Class B requirements defined in Annex A, as appropriate. An EUT which fulfils the applicable requirements specified in Annex A is deemed to fulfil the requirements in the entire frequency range from 9 kHz to 400 GHz. No measurements need be performed at frequencies where no requirement is specified.

Where this publication gives options for measuring particular requirements with a choice of measurement methods, compliance can be shown against any of the specified limits using the appropriate measurement method. In any situation where it is necessary to re-measure the equipment to show compliance with this publication, the measurement method originally chosen shall be used in order to guarantee consistency of the results, unless it is agreed by the manufacturer to do otherwise. Requirements for radiated emission measurements are defined in Table A.2 to Table A.7 with the restrictions and limitations defined in Table A.1. Requirements for conducted emission measurements are defined in Table A.9 to Table A.13 with the restrictions defined in Table A.8.

The determination of compliance with this publication shall be based solely on contributions from the EUT. For example, where an AE is required to exercise or monitor the EUT, and emissions from the AE are known to contribute to the overall measured emission of the system being assessed (for example an AE which is a plug-in module for the EUT), the AE selected should, wherever possible, be compliant with relevant emission limits. If the AE is known to cause significant emissions, these emissions may be reduced by mitigation measures, as long as these measures do not reduce the emissions from the EUT. The preferred configuration is that the AE is removed from the measurement area, as allowed by D.1.

Compliance can be shown by measuring the EUT's emissions when operating its functions simultaneously, individually in turn, or any combination thereof.

11 Measurement uncertainty

The measurement instrumentation uncertainty shall be calculated in accordance with CISPR 16-4-2 and reported as described in Clause 9.

Measurement instrumentation uncertainty shall not be taken into account in the determination of compliance. Refer to CISPR TR 16-4-3 for guidance on the applicability of the limits to a series produced MME.

Annex A (normative)

Requirements

A.1 General

The requirements for an EUT covered by this publication are given on a port by port basis in Table A.1 to Table A.13, respectively.

Throughout this annex and unless otherwise stated:

The peak detector limits in Table A.3 and Table A.5 shall not be applied to emissions produced by arcs or sparks that are high voltage breakdown events. Such emissions arise when MME devices contain or control mechanical switches that control current in inductors, or when MME devices contain or control subsystems that create static electricity (such as paper handling devices). The average limits apply to emissions from arcs or sparks. Both peak and average limits apply to other emissions from such MME devices.

Other measurement methods and associated limits for RVCs and GTEM cells are presented in Annex H for information.

Where the limit value varies over a given frequency range, it changes linearly with respect to the logarithm of the frequency. For example, a graphical representation of the AC mains power port limits defined in Table A.10 is presented in Figure A.1.

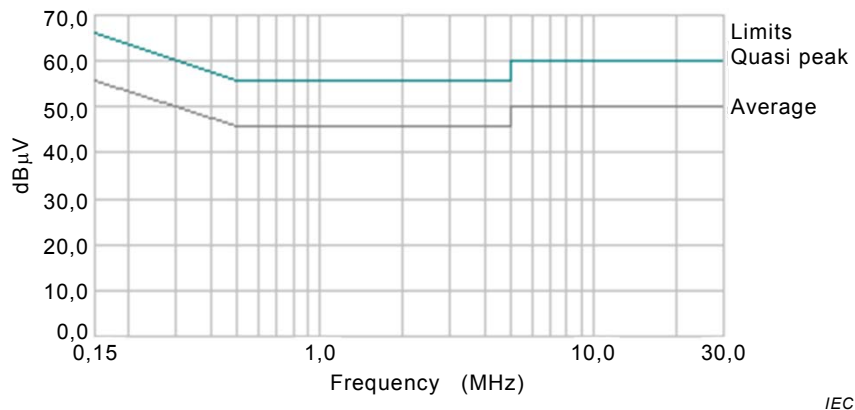

Figure A.1 – Graphical representation of the limits for the AC mains power port defined in Table A.10

- Where there is a step in the relevant limit, the lower value shall be applied at the transition frequency.
- The measurements shall be limited to:
 - a) the operating ranges of voltage and frequency as specified for the EUT, having regard to the supply voltage and frequency for the intended market of the EUT.
Measurement at two nominal voltages of 230 V (± 10 V) and 110 V (± 10 V), using a frequency of 50 Hz or 60 Hz, is normally sufficient for an EUT intended for worldwide use.
 - b) the environmental parameters (temperature, humidity and atmospheric pressure) specified for the EUT.

No additional environmental parameters are defined. It is not necessary to repeat measurements at more than one set of environmental parameters.

- If different detectors have been specified, the EUT shall be assessed using all relevant detectors against the appropriate limits. This procedure can be optimised by use of the decision trees in Figure C.3 to Figure C.5.
- For Ethernet interfaces, measurements are required at the highest data rate supported by the interface.
- The measurement facility validation shall be performed in accordance with the relevant basic standard and, for the purposes of this publication, may be limited to the frequency range where requirements are defined in Annex A.
- Equipment with a DC power port powered by a dedicated AC/DC power converter is considered to be AC mains powered equipment and shall be measured with a power converter. Where the power converter is provided by the manufacturer, the converter provided shall be used.

A.2 Requirements for radiated emissions

The EUT is deemed to comply fully with the radiated emission requirements in this publication when it has been shown to be compliant with the applicable limits as given in Table A.2 to Table A.7 using the specified requirements in the relevant table clause.⁵

Compliance may only be shown at measurement distances for which compliant measurement facility (or site) validation measurements exist for the measurement facility used.

Where limits in a frequency range are given for different types of measurement facility and/or distances, measurements only need to be performed using one combination of measurement facility and distance. The same combination shall be used for all frequencies in the range.

⁵ In this publication, table clauses are referenced using an x.y format, where x denotes the table and y denotes the referenced clause by row within the table. For example table clause A1.2 is Table A.1, clause (row) 2.

Table A.1 – Radiated emissions, basic standards and the limitation of the use of particular methods

Table clause	Measurement facility	Validation method	Measurement		Limitations and clarifications
			Procedure	Arrangement	
A1.1	SAC or OATS with weather protection cover	5.3 of CISPR 16-1-4:2010/AMD1:2012	7.3 of CISPR 16-2-3:2010	Annex D	<p>The maximum width of the EUT, local AE and associated cabling shall be within the test volume as demonstrated during the NSA test site validation.</p> <p>The validated measurement volume does not need to encompass any local AE and associated cabling which are located below the RGP or turntable, or remotely located, as described in D.1.</p> <p>NSA verification figures for 5 m facilities are presented in Table C.3.</p>
A1.2	OATS without weather protection cover	5.2 of CISPR 16-1-4:2010/AMD1:2012	7.3 of CISPR 16-2-3:2010	Annex D	NSA verification figures for 5 m facilities are presented in Table C.3.
A1.3	FSOATS	8.3 of CISPR 16-1-4:2010/AMD1:2012	7.6.6 of CISPR 16-2-3:2010	Annex D	<p>A facility validated against the FSOATS requirements shall be used for measurements above 1 GHz.</p> <p>The EUT, local AE and associated cabling shall be within the measurement volume as demonstrated during the test site validation.</p> <p>An FSOATS may be a SAC/OATS with RF absorber on the RGP or a FAR.</p>
A1.4	FAR	5.4.7 of CISPR 16-1-4:2010/AMD1:2012	Annex C and 7.4 of CISPR 16-2-3:2010	Annex D	<p>This table clause applies to radiated emission measurement up to 1 GHz for an EUT set-up in the table top arrangement as shown Figure D.11 and Figure D.12.</p> <p>Where the same room is to be used for radiated emission testing above 1 GHz, apply table clause A.3 and use the room as a FSOATS.</p> <p>The maximum width and height of an EUT, local AE including cables connected to local AE shall be less than half of the measurement distance as demonstrated during the test site validation.</p> <p>Where relevant, the height of the EUT includes 0,8 m of vertically exposed cable.</p> <p>Where relevant, the width of the EUT includes 0,8 m of horizontally exposed cable.</p>
<p>NOTE As per Clause 2, the version of CISPR 16-1-4 is CISPR 16-1-4:2010 /AMD 1:2012. The version of CISPR 16-2-3 is CISPR 16-2-3:2010/ AMD 1:2010.</p>					

Table A.2 – Requirements for radiated emissions at frequencies up to 1 GHz for class A equipment

Table clause	Frequency range MHz	Measurement			Class A limits dB(μ V/m)
		Facility (see Table A.1)	Distance m	Detector type / bandwidth	
A2.1	30 to 230	OATS/SAC	10	Quasi Peak / 120 kHz	40
	230 to 1 000				47
A2.2	30 to 230	OATS/SAC	3		50
	230 to 1 000				57
A2.3	30 to 230	FAR	10	42 to 35	
	230 to 1 000			42	
A2.4	30 to 230	FAR	3	52 to 45	
	230 to 1 000			52	

Apply only A2.1 or A2.2 or A2.3 or A2.4 across the entire frequency range.

Table A.3 – Requirements for radiated emissions at frequencies above 1 GHz for class A equipment

Table clause	Frequency range MHz	Measurement			Class A limits dB(μ V/m)
		Facility (see Table A.1)	Distance m	Detector type / bandwidth	
A3.1	1 000 to 3 000	FSOATS	3	Average / 1 MHz	56
	3 000 to 6 000				60
A3.2	1 000 to 3 000			Peak / 1 MHz	76
	3 000 to 6 000				80

Apply A3.1 and A3.2 across the frequency range from 1 000 MHz to the highest required frequency of measurement derived from Table 1.

Table A.4 – Requirements for radiated emissions at frequencies up to 1 GHz for class B equipment

Table clause	Frequency range MHz	Measurement			Class B limits dB(μ V/m)
		Facility (see Table A.1)	Distance m	Detector type / bandwidth	
A4.1	30 to 230	OATS/SAC	10	Quasi Peak / 120 kHz	30
	230 to 1 000				37
A4.2	30 to 230	OATS/SAC	3		40
	230 to 1 000				47
A4.3	30 to 230	FAR	10	32 to 25	
	230 to 1 000			32	
A4.4	30 to 230	FAR	3	42 to 35	
	230 to 1 000			42	

Apply only table clause A4.1 or A4.2 or A4.3 or A4.4 across the entire frequency range.

These requirements are not applicable to the local oscillator and harmonics frequencies of equipment covered by Table A.6.

Table A.5 – Requirements for radiated emissions at frequencies above 1 GHz for class B equipment

Table clause	Frequency range MHz	Measurement			Class B limits dB(μ V/m)
		Facility (see Table A.1)	Distance m	Detector type/ bandwidth	
A5.1	1 000 to 3 000	FSOATS	3	Average/ 1 MHz	50
	3 000 to 6 000				54
A5.2	1 000 to 3 000			Peak/ 1 MHz	70
	3 000 to 6 000				74

Apply A5.1 and A5.2 across the frequency range from 1 000 MHz to the highest required frequency of measurement derived from Table 1.

Table A.6 – Requirements for radiated emissions from FM receivers

Table Clause	Frequency Range MHz	Measurement			Class B Limit dB(μ V/m)			
		Facility (see Table A.1)	Distance m	Detector type / Bandwidth	Fundamental	Harmonics		
A6.1	30 to 230	OATS/SAC	10	Quasi Peak / 120 kHz	50	42		
	230 to 300					42		
	300 to 1 000					46		
A6.2	30 to 230	OATS/SAC	3		Quasi Peak / 120 kHz	60	52	
	230 to 300						52	
	300 to 1 000						56	
A6.3	30 to 230	FAR	10	Quasi Peak / 120 kHz		52 to 45	44 to 37	
	230 to 300						45	37
	300 to 1 000						45	41
A6.4	30 to 230	FAR	3		Quasi Peak / 120 kHz	62 to 55	54 to 47	
	230 to 300						55	47
	300 to 1 000						55	51

Apply only A6.1 or A6.2 or A6.3 or A6.4 across the entire frequency range.

These relaxed limits apply only to emissions at the fundamental and harmonic frequencies of the LO. Signals at all other frequencies shall be compliant with the limits given in Table A.4.

Table A.7 – Requirements for outdoor units of home satellite receiving systems

Table Clause	Frequency Range MHz	Measurement			Class B Limits	Applicable to
		Facility (see Table A.1)	Distance m	Detector type / Bandwidth		
A7.1	30 to 1 000	SAC / OATS / FAR	See Table A.4	Quasi Peak / 120 kHz	See Table A.4	
A7.2	1 000 to 2 500	FSOATS	3	Average / 1 MHz	50 dB(μ V/m)	LO leakage and spurious radiated emissions from the EUT, in the region outside $\pm 7^\circ$ of the main beam axis. See Figure H.1
	2 500 to 18 000				64 dB(μ V/m)	
A7.3	1 000 to 18 000	FSOATS	3	Average / 1 MHz	37 dB(μ V/m)	LO leakage from the EUT, in the region within $\pm 7^\circ$ of the main beam axis. See Figure H.1
A7.4	1 000 to 18 000	Conducted (Clause H.4)	n/a	Average / 1 MHz	30 dBpW	

For details of the EUT configuration, see Annex H.

For radiated emissions measurements at frequencies up to 1 GHz, the requirements defined in Table A.4 shall be satisfied.

Apply the appropriate limits across the entire frequency range.

Apply the limits defined in table Clause A7.1 and A7.2. Also apply the limits defined in either table Clause A7.3 or A7.4.

A.3 Requirements for conducted emissions

The EUT is deemed to comply with the conducted emission requirements when it has been shown to be compliant with all applicable limits as given in Table A.9 to Table A.13. The required measurement methods are stated in Table A.8.

Table A.8 – Conducted emissions, basic standards and the limitation of the use of particular methods

Table clause	Coupling device	Basic standard	Validation method	Measurement arrangement	Measurement procedure and clarifications
A8.1	AMN	Clause 7 of CISPR 16-2-1:2008	Clause 4 of CISPR 16-1-2:2003	Annex D	Use the measurement procedures defined in C.3. The impedance and phase requirements of CISPR 16-1-2 in the range 0,15 MHz to 30 MHz apply.
A8.2	AAN	Clause 7 of CISPR 16-2-1:2008	Clause 7 of CISPR 16-1-2:2003 applying the requirements of Table C.2. of this standard	Annex D and C.4.1.1	Use the measurement procedures defined in Clause C.3 and C.4.1.1. Using the clarifications in Clause C.3.6.
A8.3	Current probe	Clause 7 of CISPR 16-2-1:2008	5.1 of CISPR 16-1-2:2003	Annex D and C.4.1.1	
A8.4	CVP	Clause 7 of CISPR 16-2-1:2008	5.2.2 of CISPR 16-1-2:2003	Annex D and C.4.1.1	
A8.5	Matching and combining networks for voltage measurement into 75 Ω	n/a	C.4.2	C.4.2	Use the measurement procedures defined in C.4.2 for the measurement of the unwanted emission voltages at a TV/FM broadcast receiver tuner port
A8.6	Matching network for voltage measurement into 75 Ω	n/a	C.4.3	C.4.3	Use the measurement procedures defined in C.4.3 for wanted signal and emission voltage at the RF modulator output port.
NOTE As per Clause 2, the version of CISPR 16-1-2 is CISPR 16-1-2:2003/ AMD 1:2004/ AMD 2:2006. The version of CISPR 16-2-1 is CISPR 16-2-1:2008/ AMD 1:2010 /AMD2:2013.					

Table A.9 – Requirements for conducted emissions from the AC mains power ports of Class A equipment

Applicable to				
1. AC mains power ports (3.1.1)				
Table clause	Frequency range MHz	Coupling device (see Table A.8)	Detector type / bandwidth	Class A limits dB(μ V)
A9.1	0,15 to 0,5	AMN	Quasi Peak / 9 kHz	79
	0,5 to 30			73
A9.2	0,15 to 0,5	AMN	Average / 9 kHz	66
	0,5 to 30			60
Apply A9.1 and A9.2 across the entire frequency range.				

Table A.10 – Requirements for conducted emissions from the AC mains power ports of Class B equipment

Applicable to				
1. AC mains power ports (3.1.1)				
Table clause	Frequency range MHz	Coupling device (see Table A.8)	Detector type / bandwidth	Class B limits dB(μV)
A10.1	0,15 to 0,5	AMN	Quasi Peak / 9 kHz	66 to 56
	0,5 to 5			56
	5 to 30			60
A10.2	0,15 to 0,5	AMN	Average / 9 kHz	56 to 46
	0,5 to 5			46
	5 to 30			50

Apply A10.1 and A10.2 across the entire frequency range.

Table A.11 – Requirements for asymmetric mode conducted emissions from Class A equipment

Applicable to					
1. wired network ports (3.1.32)					
2. optical fibre ports (3.1.25) with metallic shield or tension members					
3. antenna ports (3.1.3)					
Table clause	Frequency range MHz	Coupling device (see Table A.8)	Detector type / bandwidth	Class A voltage limits dB(μV)	Class A current limits dB(μA)
A11.1	0,15 to 0,5	AAN	Quasi Peak / 9 kHz	97 to 87	n/a
	0,5 to 30			87	
	0,15 to 0,5	AAN	Average / 9 kHz	84 to 74	
	0,5 to 30			74	
A11.2	0,15 to 0,5	CVP and current probe	Quasi Peak / 9 kHz	97 to 87	53 to 43
	0,5 to 30			87	43
	0,15 to 0,5	CVP and current probe	Average / 9 kHz	84 to 74	40 to 30
	0,5 to 30			74	30
A11.3	0,15 to 0,5	Current Probe	Quasi Peak / 9 kHz	n/a	53 to 43
	0,5 to 30				43
	0,15 to 0,5	Current Probe	Average / 9 kHz		40 to 30
	0,5 to 30				30

The choice of coupling device and measurement procedure is defined in Annex C.

AC mains ports that also have the function of a wired network port shall meet the limits given in Table A.9.

The measurement shall cover the entire frequency range.

The application of the voltage and/or current limits is dependent on the measurement procedure used. Refer to Table C.1 for applicability.

Testing is required at only one EUT supply voltage and frequency.

Applicable to ports listed above and intended to connect to cables longer than 3 m.

Table A.12 – Requirements for asymmetric mode conducted emissions from Class B equipment

Applicable to					
1. wired network ports (3.1.32) 2. optical fibre ports (3.1.25) with metallic shield or tension members 3. broadcast receiver tuner ports (3.1.8) 4. antenna ports (3.1.3)					
Table clause	Frequency range MHz	Coupling device (see Table A.8)	Detector type / bandwidth	Class B voltage limits dB(μV)	Class B current limits dB(μA)
A12.1	0,15 to 0,5	AAN	Quasi Peak / 9 kHz	84 to 74	n/a
	0,5 to 30			74	
	0,15 to 0,5	AAN	Average / 9 kHz	74 to 64	
	0,5 to 30			64	
A12.2	0,15 to 0,5	CVP and current probe	Quasi Peak / 9 kHz	84 to 74	40 to 30
	0,5 to 30			74	30
	0,15 to 0,5	CVP and current probe	Average / 9 kHz	74 to 64	30 to 20
	0,5 to 30			64	20
A12.3	0,15 to 0,5	Current Probe	Quasi Peak / 9 kHz	n/a	40 to 30
	0,5 to 30				30
	0,15 to 0,5	Current Probe	Average / 9 kHz		30 to 20
	0,5 to 30				20
<p>The choice of coupling device and measurement procedure is defined in Annex C.</p> <p>Screened ports including TV broadcast receiver tuner ports are measured with a common-mode impedance of 150 Ω. This is typically accomplished with the screen terminated by 150 Ω to earth.</p> <p>AC mains ports that also have the function of a wired network port shall meet the limits given in Table A.10.</p> <p>The measurement shall cover the entire frequency range.</p> <p>The application of the voltage and/or current limits is dependent on the measurement procedure used. Refer to Table C.1 for applicability.</p> <p>Measurement is required at only one EUT supply voltage and frequency.</p> <p>Applicable to ports listed above and intended to connect to cables longer than 3 m.</p>					

Table A.13 – Requirements for conducted differential voltage emissions from Class B equipment

Applicable to						
1. TV broadcast receiver tuner ports (3.1.8) with an accessible connector						
2. RF modulator output ports (3.1.29)						
3. FM broadcast receiver tuner ports (3.1.8) with an accessible connector						
Table clause	Frequency range MHz	Detector type/ bandwidth	Class B limits dB(μ V) 75 Ω			Applicability
			Other	Local Oscillator Fundamental	Local Oscillator Harmonics	
A13.1	30 to 950	For frequencies ≤ 1 GHz	46	46	46	See ^a
	950 to 2 150		46	54	54	
A13.2	950 to 2 150	Quasi Peak/ 120 kHz	46	54	54	See ^b
A13.3	30 to 300		For frequencies ≥ 1 GHz	46	54	50
	300 to 1 000	52				
A13.4	30 to 300	Peak/ 1 MHz	46	66	59	See ^d
	300 to 1 000				52	
A13.5	30 to 950	Peak/ 1 MHz	46	76	46	See ^e
	950 to 2 150			n/a	54	

^a Television receivers (analogue or digital), video recorders and PC TV broadcast receiver tuner cards working in channels between 30 MHz and 1 GHz, and digital audio receivers.

^b Tuner units (not the LNB) for satellite signal reception.

^c Frequency modulation audio receivers and PC tuner cards.

^d Frequency modulation car radios.

^e Applicable to EUTs with RF modulator output ports (for example DVD equipment, video recorders, camcorders and decoders etc.) designed to connect to TV broadcast receiver tuner ports. Limits specified for the LO are for the RF modulator carrier signal and harmonics.

The term 'other' refers to all emissions other than the fundamental and the harmonics of the LO.

The measurement shall cover the entire frequency range.

The EUT shall be tuned in accordance with Table B.3 and clause C.4.2.1.

Annex B (normative)

Exercising the EUT during measurement and test signal specifications

B.1 General

This annex specifies the methods for exercising the EUT during the emission measurements.

MME typically have several different functions and numerous modes of operation associated with each function.

For each function, or group of functions selected to exercise the EUT, a number of representative modes of operation, including low power/standby mode, shall be considered for testing. The mode(s) that produce(s) the highest emissions shall be selected for the final measurements.

The EUT shall be operated in the selected mode(s) while the ports are exercised in accordance with this annex.

The emissions from the various ports (as required by this publication) shall be measured while appropriate test signals are applied as specified in this annex.

All ports, including loudspeakers and display devices, shall be exercised in a manner consistent with, and representative of, normal use. Exercising signals, audio levels and display parameters shall be chosen having regard to the intended function of the EUT and shall be such as to allow the correct operation of the EUT to be assessed.

Subsequent clauses give further clarification to aid reproducibility between laboratories. A description of the methods used to exercise the EUT and all relevant ports shall be recorded in the test report. Where a deviation in the application of one of the methods defined in this annex is used (for example using a different signal level or image), a justification shall be included in the test report.

B.2 Exercising of EUT ports

B.2.1 Audio signals

For EUTs that support audio signals, the signal used to exercise the EUT shall be a 1 kHz sinusoidal signal unless otherwise specified as more appropriate by the manufacturer.

B.2.2 Video signals

EUTs that display video images or EUTs with ports that are used to provide video signals shall be exercised in accordance with Table B.1 and configured, where possible, using the parameters given in Table B.2.

Video ports shall output signals, and images shall be displayed, corresponding to the highest complexity level listed in Table B.1 that the EUT is capable of generating. However, the manufacturer may choose to exercise the displays and video ports using the text image given in Table B.1 (Complexity level 2) where emission levels using this text image are not reduced in comparison to emission levels obtained using Complexity levels 3 or 4.

Table B.1 – Methods of exercising displays and video ports

Complexity Level	Display image	Description	Examples of equipment
4 (Most)	Colour bars with moving picture element	Standard colour bar image with a small moving element. See ^a .	Digital television set, set-top box, personal computer, DVD equipment, video game console, standalone monitor.
3	Colour bars	Standard colour bar image. See ^a .	Analogue television set, display on camera, display on photo printer.
2	Text image	Where possible a pattern consisting of all H characters shall be displayed. The character size and number of characters per line shall be set so that typically the greatest number of characters per screen is displayed. If text scrolling is supported on the display, the text shall scroll	POS terminal, computer terminal without graphic capability.
1 (Least)	Typical display	The most complex display that can be generated by the EUT.	An EUT with proprietary displays and/or not capable of displaying any of the above images, electronic music keyboard, telephone.

^a This display image is also valid for monochrome displays which will display grey scale bars.

When there is more than one display or video port, each display/port shall be exercised appropriately subject to the provisions of B.2.2.

The display images may be modified, when necessary to exercise primary functions of the EUT. Where possible, these modifications should be restricted to the bottom or top half of the display area so that the image defined in the table fills the majority of the display.

For analogue television sets, only colour bars should be displayed, defined in complexity 3.

Examples of colour bars required in complexity 3 and 4 are 100/0/100/0 or 100/0/75/0 bars as specified in ITU-R Recommendation BT.471-1.

Table B.2 – Display and video parameters

Function	Setting
Hardware acceleration	Maximum.
Screen settings	Highest effective resolution (including the settings for pixel and frame rate).
Colour quality	Highest colour bit depth.
Brightness, contrast, colour saturation	Use either the factory default settings or typical settings.
Other	Adjusted to obtain a typical picture using settings giving the highest performance.

B.2.3 Digital broadcast signals

Examples of digital broadcast signal specifications are shown in Table B.4.

B.2.4 Other signals

Other ports shall be exercised using the methods defined in Table B.3.

Table B.3 – Methods used to exercise ports

Port	Methods used to exercise port
Broadcast receiver tuner port	<p>The modulation of the RF signal carrier shall be set according to the system for which the EUT is intended.</p> <p>Unless otherwise defined, the input signal level at the relevant ports shall be sufficient to provide a noise-free picture and/or audio</p> <p>In addition refer to B.2.1 and B.2.2</p> <p>Examples of digital broadcast signal specifications for digital broadcast receiver ports are given in Table B.4.</p> <p>The radiated emissions and mains power port conducted emissions from an EUT with broadcast reception functionality shall be assessed when tuned to one channel in each reception mode, for example: analogue TV, DVB-T, DVB-C, analogue radio, digital radio etc.</p> <p>For guidance on how to determine channel/s for conducted measurements on the broadcast receiver tuner port see C.4.2.1.</p>
Wired network port	<p>A representative signal shall be defined by the manufacturer.</p> <p>For ports supporting Ethernet traffic (for example 100Base-T, 1000Base-T), that can operate at multiple rates, measurements may be limited to mode in which the EUT operates at its maximum rate.</p> <p>When assessing an EUT transmitting 10Base-T Ethernet traffic, apply the following:</p> <p>In order to make reliable emission measurements representative of high LAN utilization it is only necessary to create a condition of LAN utilization in excess of 10 % and sustain that level for a minimum of 250 ms. The content of the test traffic should consist of both periodic and pseudo-random messages in order to emulate realistic types of data transmission. (Examples of pseudo-random messages: files that are compressed or encrypted.</p> <p>Examples of periodic messages: uncompressed graphic files, memory dumps, screen updates, disk images.) If the LAN maintains transmission during idle periods, measurements shall also be made during idle periods.</p>
All other ports not defined above	A representative signal shall be defined by the manufacturer.

Table B.4 – Examples of digital broadcast signal specifications

General	DVB	ISDB	ATSC	DMB-T
Standard	TR 101154	-	ATSC Standard A/65	System-A (DAB/Eureka-147)
Source coding	MPEG-2 video MPEG-2 audio	MPEG-2 video MPEG-2 audio	MPEG-2 video AC-3 audio	H.264/MPEG-4 AVC
Data coding	Optional	Optional	Optional	Optional
Video elementary stream	Colour bar, with small moving element	Colour bar, with small moving element	Colour bar, with small moving element	Colour bar, with small moving element
Video bit rate	6 MBit/s	6 MBit/s	6 MBit/s	(1 ~ 11) Mbit/s
Audio elementary stream for reference measurement	1 kHz/full range –6 dB	1 kHz/full range –6 dB	1 kHz/full range –6 dB	1 kHz/full range –6 dB
Audio elementary stream for noise measurement	1 kHz/silence	1 kHz/silence	1 kHz/silence	1 kHz/silence
Audio bit rate	192 kbit/s	192 kbit/s	192 kbit/s	192 kbit/s
Terrestrial TV	DVB-T	ISDB-T	ATSC	DMB-T
Standard	EN 300 744	ARIB STD-B21 ARIB STD-B31	ATSC 8VSB	System-A (DAB/Eureka-147)
Level	50 dB(μV)/75 Ω-VHF B III 54 dB(μV)/75 Ω-UHF B IV/V	34 dB(μV) to 89 dB(μV)/75 Ω	54 dB(μV) (using ATSC 64)	18 dB(μV) ~ 97 dB(μV)
Channel	6 to 69	-	2 to 69	-
Frequency	-	470 MHz to 770 MHz, 5,7 MHz bandwidth	-	174 MHz ~ 216 MHz
Modulation	OFDM	OFDM	8 VSB or 16 VSB	DQPSK, Transmission: OFDM
Mode	2 k or 8 k	8k, 4k, 2k	-	-
Modulation scheme	16 or 64 QAM or QPSK	QPSK, DQPSK, 16 QAM, 64 QAM	-	-
Guard interval	1/4, 1/8, 1/16, 1/32	1/4, 1/8, 1/16, 1/32	-	-
Code rate	1/2, 2/3, 3/4, 5/6, 7/8	1/2, 2/3, 3/4, 5/6, 7/8	2/3	-
Useful bit rate	Variable MBits	-	19,39 MBit/s	-
Information bit rate: max	31,668 MBit/s	23,234 MBit/s	-	-
Satellite TV	DVB-S	DVB-S (Communication satellite)	ISDB-S(Broadcasting satellite)	None
Specification	EN 300 421	ARIB STD-B1	ARIB STD-B20 ARIB STD-B21	-
Level	60 dB(μV)/75 Ω	48 dB(μV) to 81 dB(μV)/75 Ω	48 dB(μV) to 81 dB(μV)/75 Ω	-
Frequency	0,95 GHz to 2,15 GHz	12,2 GHz to 12,75 GHz	11,7 GHz to 12,2 GHz	-
Frequency 1 st IF	-	1 000 MHz to 1 550 MHz, 27 MHz bandwidth	1 032 MHz to 1 489 MHz, 34,5 MHz bandwidth	-
	-	12,5 GHz to 12,75 GHz	11,7 GHz to 12,2 GHz	-
Modulation	QPSK	QPSK	TC8PSK, QPSK, BPSK	-
Code Rate	3/4	1/2, 2/3, 3/4, 5/6, 7/8	2/3(TC8PSK), 1/2, 2/3, 3/4, 5/6, 7/8(QPSK,	-

General	DVB	ISDB	ATSC	DMB-T
			BPSK)	
Useful bit rate	38,015 MBit/s	29,2 MBits/s ($r = 3/4$)	-	-
Information bit rate	-	19,4 MBit/s to 34,0 MBit/s	-	-
Information bit rate: max	-	34,0 MBit/s	52,17 MBit/s	-
Cable TV	DVB-C	ISDB-C	ATSC	-
Specification	EN 300 429 ES 201 488 ES 202 488-1 EN 302 878 (DOCSIS)	JCTEA STD-002 JCTEA STD-007	ANSI/SCTE 07	-
Level	67 dB μ V at 75 Ω for 256 QAM 60 dB μ V at 75 Ω for 64 QAM	49 dB(μ V) to 81 dB(μ V)/75 Ω (64 QAM) TDB (256 QAM)	60 dB(μ V)/75 Ω	-
Frequency	110 MHz to 862 MHz	90 MHz to 770 MHz, 6 MHz bandwidth	88 MHz to 860 MHz	-
Modulation	16/32/64/128/256 QAM	64 QAM or 256 QAM	64 QAM or 256 QAM	-
Useful bit rate	38,44 MBit/s (64 QAM) and 51,25 MBit/s (256 QAM) at 6,952 Mbaud (8 MHz channel)	-	26,970 MBit/s (64 QAM), 38,810 MBit/s (256 QAM)	-
Transmission bit rate	41,71 MBit/s (64 QAM) 55,62 MBit/s (256 QAM) at 6,952 Mbaud (8 MHz channel)	31,644 MBit/s (64 QAM) 42,192 MBit/s (256 QAM)	-	-
Information bit rate	51,25 MBit/s (256 QAM) at 6,952 Mbaud (8 MHz channel)	29,162 MBits/s 38,883 MBits/s (256 QAM)	-	-
Return path	-	-	5 MHz to 40 MHz, QPSK	-

Annex C (normative)

Measurement procedures, instrumentation and supporting information

C.1 General

This annex provides additional information, measurement procedures and requirements to supplement the normative references defined in Table A.1 and Table A.8. Further supporting information is also provided in Annex G (informative).

This annex is divided into 3 main clauses:

- C.2 Instrumentation and supporting information;
- C.3 General measurement procedures;
- C.4 MME-related measurement procedures.

C.2 Instrumentation and supporting information

C.2.1 General

Each piece of measurement apparatus shall comply with the relevant requirements defined in the basic standards given in Table A.1 and Table A.8.

C.2.2 Using CISPR 16 series as the basic standard

C.2.2.1 General

The measuring receiver shall meet the relevant specifications of CISPR 16-1-1:2010, defined in Clause 2. Detectors and bandwidths shall be used as specified in relevant tables in Annex A. Where this publication specifies the use of an average detector, the linear average detector defined in Clause 6 of CISPR 16-1-1:2010 shall be used.

If the level of an isolated emission exceeds any relevant limit, it shall be ignored, provided that the following two conditions are met when measured over a two minute interval:

- 1) the emission does not exceed the limit for more than 1 s;
- 2) the emission does not exceed the limit more than once in any 15 s observation period.

Care shall be taken to avoid overloading the measurement system. See Annex E.

Measurement instruments provided with RF preselectors, which automatically follow the frequency being scanned, shall have a sufficiently long measurement time on each frequency to avoid errors in the measured amplitude values.

When using spectrum analysers during prescan (see C.3.2) measurements, the video bandwidth of the measurement instrument should be equal to, or greater than, the resolution bandwidth in order not to influence the measurement results. Other settings of resolution and video bandwidth may be used, but care should be taken to ensure the settings do not adversely influence the results.

C.2.2.2 Antennas for radiated emissions measurements

Any suitable broadband linearly polarised antenna or tuned dipole may be used during measurements. These shall be calibrated in free space conditions using the procedures in ANSI C63.5.

C.2.2.3 Ambient signals

If ambient signals are masking EUT emissions then the procedure defined in Annex A of CISPR 16-2-3:2010/AMD1:2010 shall be used to reduce the impact of each ambient. The frequencies and levels of the ambient signals masking EUT emissions shall be recorded in the test report.

C.2.2.4 Boundary of the EUT, local AE and associated cabling and measurement distance for radiated emissions measurements

The EUT and local AE shall be arranged in the most compact practical arrangement within the test volume, while respecting typical spacing and the requirements defined in Annex D. The central point of the arrangement shall be positioned at the centre of the turntable. The measurement distance is the shortest horizontal distance between an imaginary circular periphery just encompassing this arrangement and the calibration point of the antenna. See Figure C.1 and Figure C.2.

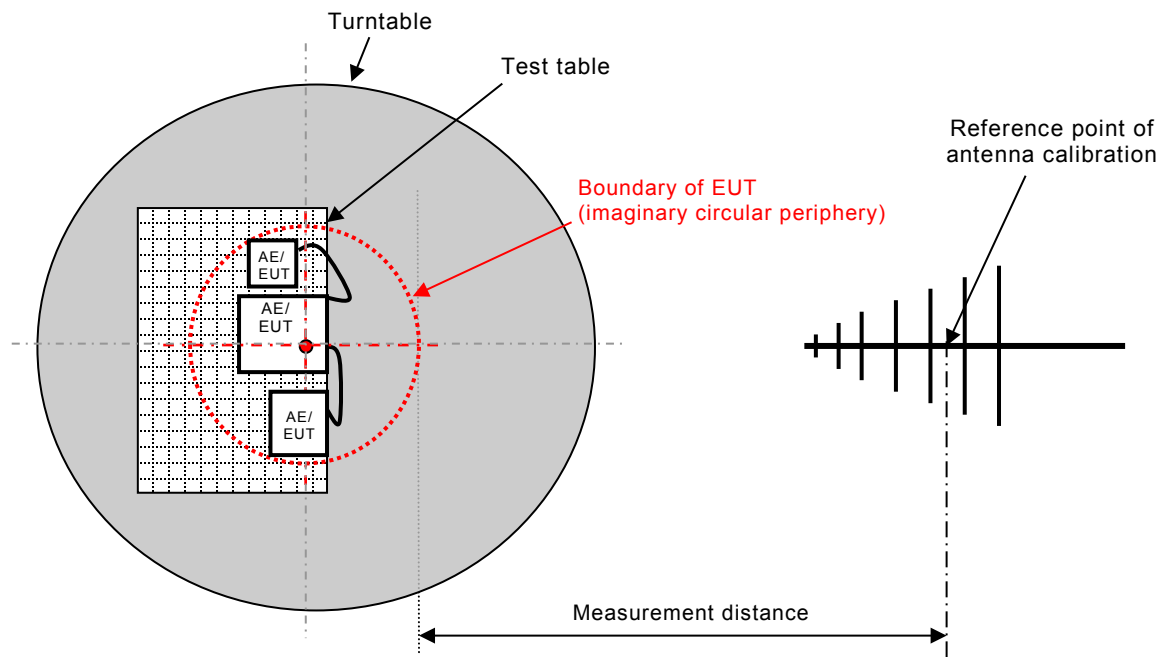

IEC

Figure C.1 – Measurement distance

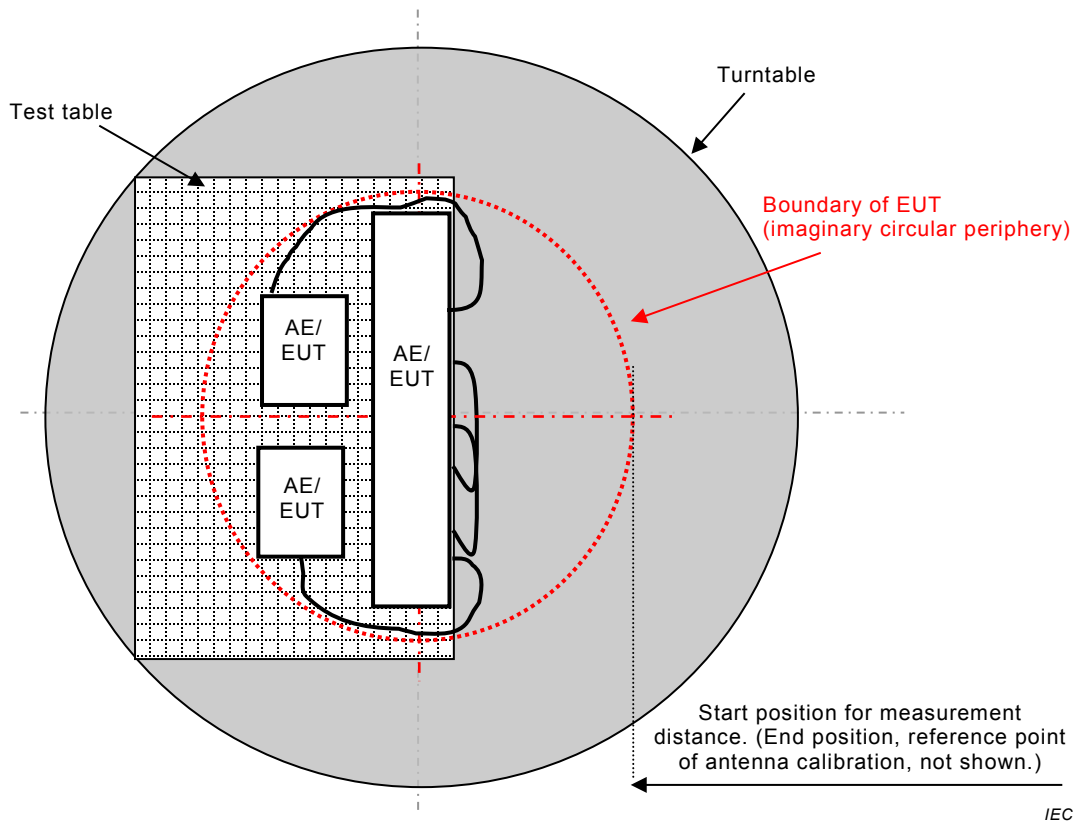

Figure C.2 – Boundary of EUT, Local AE and associated cabling

Where possible any HID should be placed in a typical arrangement. HID may be placed at the front edge of the table if the table is not deeper than 1 m. If a deeper table is used, the HID may only be placed at the front edge if this does not increase the size of the imaginary circular periphery, otherwise the HID may be placed at a distance of 1 m from the back edge of the table to the front of the HID.

Where AE is placed outside the measurement area (as described in D.1.1), this remotely located AE and its associated cabling shall not be considered to be within the circular periphery for the purposes of defining the measurement distance.

Where a test facility has been validated (in accordance with Tables 1 and 2 of CISPR 16-1-4:2010/AMD1:2012 or in C.4.4) for a different measurement distance not defined in Table A.2 to Table A.7, the measurement may be performed at that distance. In this case the limit L_2 , corresponding to the selected measurement distance d_2 , shall be calculated by applying the following formula:

$$L_2 = L_1 + 20 \log(d_1/d_2)$$

Where L_1 is the specified limit in $\text{dB}\mu\text{V}/\text{m}$ at the distance d_1 ; and, L_2 is the new limit for distance d_2 . The distances d_1 and d_2 use the same unit, such as m.

In addition, when using this formula, the test report shall show the limit L_2 and the actual measurement distance d_2 . To ensure consistency of calculation, wherever possible the limits for the 10 m measurement distance (up to 1 GHz) and the 3 m measurement distance (above 1 GHz) shall be used as the basis for calculations of limits at other measurement distances.

The minimum measurement distance for radiated emission measurement for frequencies below 1 GHz shall be 3 m and for frequencies above 1 GHz shall be 1 m.

When using a FAR and the position of the receiving antenna cannot be changed, then the limits shall be adjusted based on the above defined formula.

C.2.3 EUT cycle time and measurement dwell time

The cycle time is the period for the EUT to complete one entire operation. A dwell time longer than the cycle time shall normally be used during all formal measurements. The dwell time may be limited to 15 s.

C.3 General measurement procedures

C.3.1 Overview

The radiated and conducted emissions shall be assessed against the relevant requirements in Annex A, using the appropriate procedures defined in Table A.1 and Table A.8. The following subclauses provide a general overview taking into account the test facilities where the measurements are performed. Further information is also contained in C.4 and Annex G.

In order to speed-up the measurement procedure, peak detectors may be used in accordance with the decision trees defined in Figure C.3 to Figure C.5.

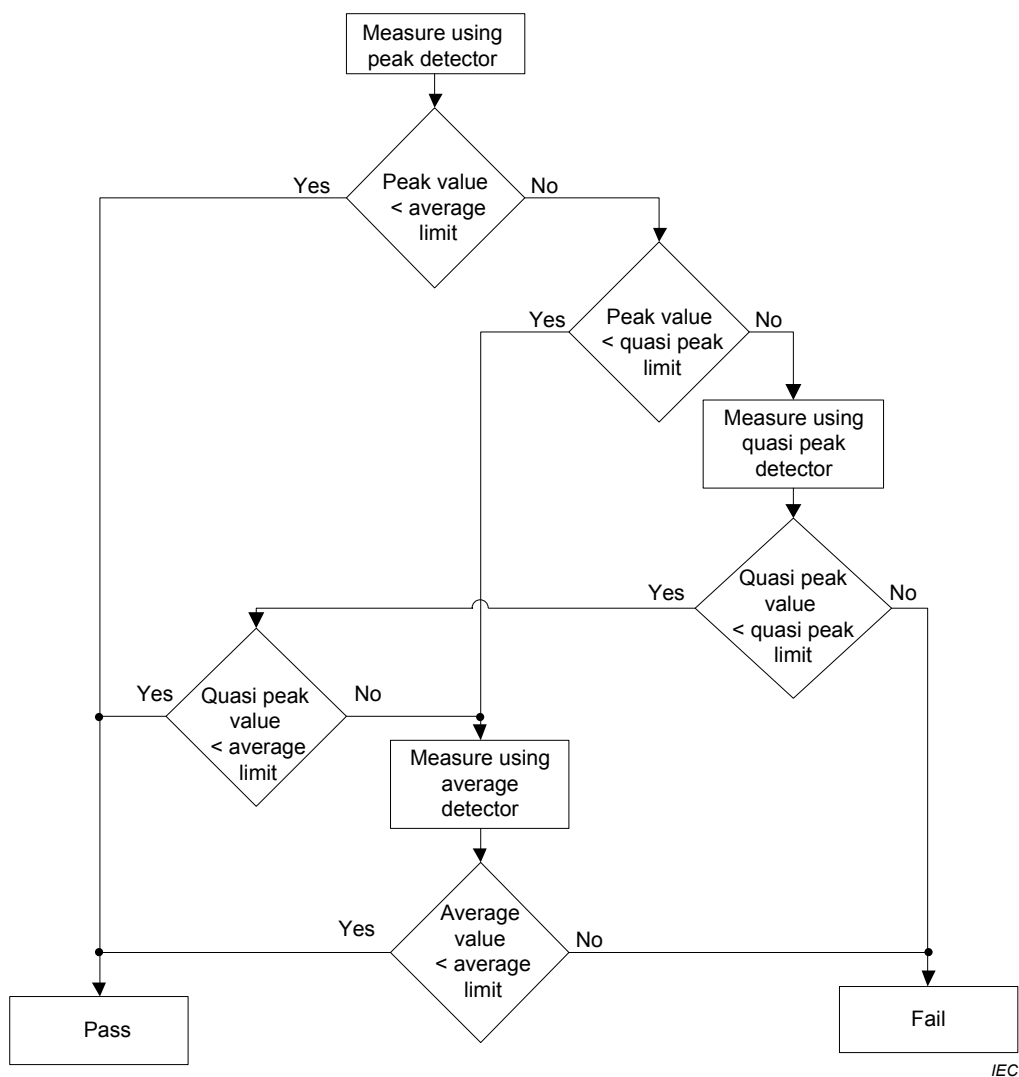

Figure C.3 – Decision tree for using different detectors with quasi peak and average limits

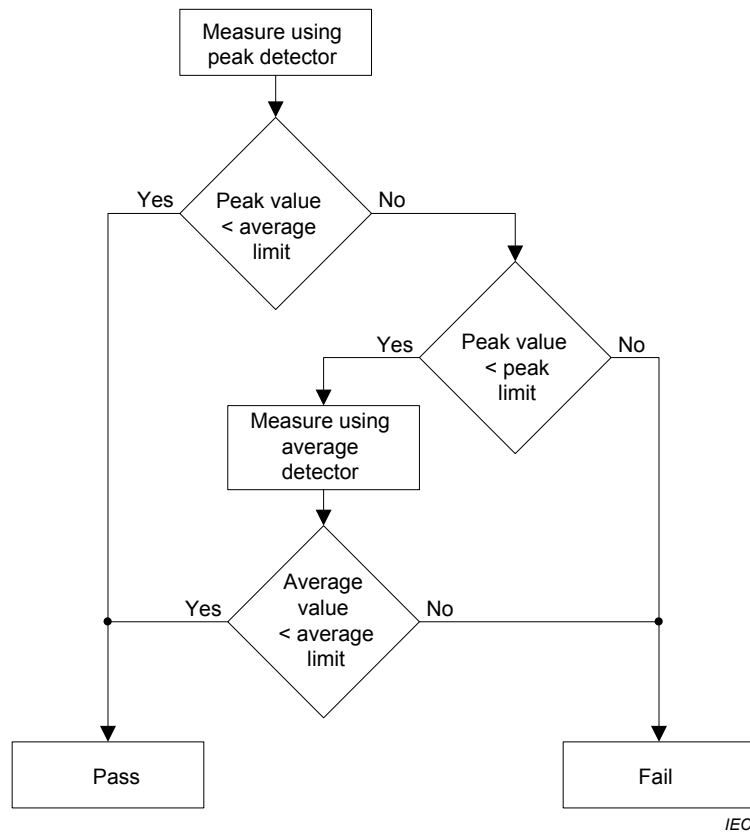

Figure C.4 – Decision tree for using different detectors with peak and average limits

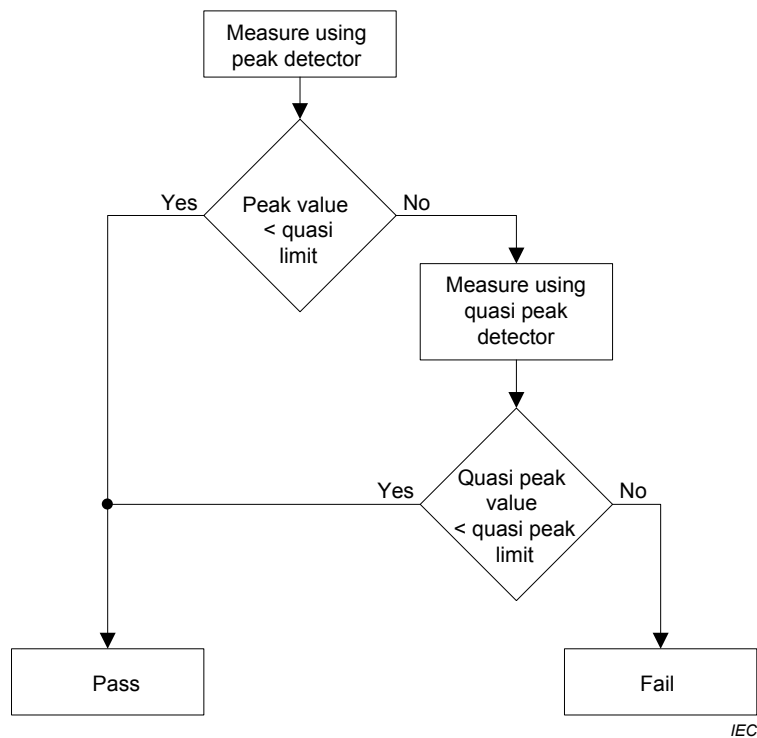

Figure C.5 – Decision tree for using different detectors with a quasi-peak limit

C.3.2 Prescan measurements

The purposes of a prescan measurement are to determine the frequencies at which the EUT produces the highest level of emissions and to help select the configuration(s) to be used in the formal measurements. For details on prescan measurements refer to Annex E.

C.3.3 Formal measurements

The configuration(s) found during the prescan measurement that produce(s) the highest amplitude emission relative to the limit shall be used for the formal measurement. Where prescan measurements have not been performed, the formal measurements shall be performed using the configuration(s) that are expected to produce the highest amplitude emissions relative to the limit; and, the reasons for the selection shall be given in the test report.

The formal measurements shall be performed using a compliant measurement facility as defined in Table A.1 and Table A.8. The measurements shall be performed in accordance with the basic standards and the requirements of this document.

Where measurements are performed using a FAR, the antenna together with the cable may be moved to achieve the specified measurement distance.

C.3.4 Specifics for radiated emission measurements

Formal emissions measurements shall determine the highest emission level at any frequency at which a limit is set, considering the following:

- antenna polarization (horizontal and vertical);
- full rotation of the EUT, local AE and associated cabling (through 360 degrees);
- antenna height.

Where measurements are made using an OATS/SAC, the antenna height scan shall be restricted to a range of 1 m to 4 m above the RGP.

Where measurements are made using a FSOATS, the antenna height scan shall encompass those heights defined in Figure 14, Figure 15 and Table 2 of CISPR 16-2-3:2010/AMD1:2010.

If no prescan has been performed, then the formal measurements shall be carried out across the entire frequency range.

C.3.5 Specifics for conducted emission measurements on the AC mains power ports

Testing shall include measurements on all live and neutral lines (or ports).

For guidance on elements of conducted measurements see 6.5.1 of CISPR 16-2-1:2008/ AMD 1:2010 /AMD2:2013.

C.3.6 Specifics for conducted emission measurements on analogue/digital data ports

MME may have different types of analogue/digital data ports to which different requirements apply as stated in Annex A. As a minimum, one port of each type shall be exercised and assessed against the requirements. The measurement procedures shall be selected using the information given in Table C.1 and elsewhere in this clause.

When an EUT has multiple analogue/digital data ports of the same type, at least one port of each type shall be assessed. Where it has been shown by pre-scanning or some other

technique that the ports are similar in their emission performance, only a single port need be assessed.

For guidance on elements of conducted measurements see 6.5.1 of CISPR 16-2-1:2008/ AMD 1:2010 /AMD2:2013.

C.3.7 Specifics for conducted emission measurements on broadcast receiver tuner ports

One of each port type (digital, analogue, satellite etc.) shall be assessed using the measurement procedures defined in C.4.2.

For guidance on elements of conducted measurements see 6.5.1 of CISPR 16-2-1:2008/ AMD 1:2010 /AMD2:2013.

C.3.8 Specifics for conducted emission measurements on RF modulator output ports

One of each port type shall be assessed using the measurement procedure defined in C.4.3.

For guidance on conducted measurements see 6.5.1 of CISPR 16-2-1:2008/ AMD 1:2010 /AMD2:2013.

C.4 MME-related measurement procedures

C.4.1 Measurement of conducted emissions at analogue/digital data ports

C.4.1.1 Measurement procedure selection

The purpose of these tests is to measure the common mode emission at analogue/digital data ports of an EUT. Appropriate measurement procedures are defined in Table C.1.

Table C.1 – Analogue/digital data port emission procedure selection

	Cable type	Number of pairs	Example of relevant figures	Measurement type	Procedures
1	Balanced Unscreened	1 (2 wire) 2 (4 wire) 3 (6 wire) 4 (8 wire)	Figure G.1 to Figure G.3 Figure G.2 to Figure G.5 Figure G.3 Figure G.3 or Figure G.6 or Figure G.7	Voltage	C.4.1.6.2.
2	Balanced Unscreened	Ports connected to cables with more than 4 balanced pairs or where the port is unable to function correctly when connected through an AAN.	n/a	Voltage and Current	C.4.1.6.4.
3	Screened or Coaxial	n/a	Figure G.8 Figure G.9 Figure G.10 or Figure G.11	Voltage	C.4.1.6.2.
4	Screened or Coaxial	n/a	n/a	Voltage or Current	C.4.1.6.3
5	Unbalanced cables	n/a	n/a	Voltage and Current	C.4.1.6.4
6	AC Mains	n/a	AMN CISPR 16-1-2:2003/ AMD 1:2004/ AMD 2:2006, Figure 5 and Figure 6	Voltage	Apply the requirements of Table A.9 or Table A.10, as appropriate. The AMN shall be used as a voltage probe.

Where used, an AAN shall satisfy all the requirements defined in C.4.1.2.

Where used, the current probe shall satisfy the requirements defined in C.4.1.4 and the CVP shall satisfy the requirements defined in C.4.1.5.

The mains voltage shall be supplied to the EUT via the AMN used when measuring the mains terminal emission voltages according to Table A.9 or Table A.10.

Where used the AAN shall be selected in accordance with C.4.1.3.

Care shall be taken when measuring common mode current with an AAN in the circuit to ensure that the measurement method accurately measures both the launched and converted components of the common mode current.

The procedure defined in C.4.1.6.2 gives results with lower measurement uncertainty than the procedures in C.4.1.6.3 and C.4.1.6.4

C.4.1.2 Characteristics of AAN

Measurement of common mode (asymmetric mode) current or voltage emissions at wired network ports for attachment of unscreened balanced pairs shall be performed with the wired network port connected by a cable to an AAN. The AAN shall define the common mode termination impedance seen by the wired network port during the emission measurements.

The combination of the AAN and all appropriate adapters required to connect to the EUT and AE shall have the following properties:

- a) The common mode termination impedance of the EUT port, in the frequency range 0,15 MHz to 30 MHz, shall be $150 \Omega \pm 20 \Omega$, phase angle $0 \pm 20^\circ$.
- b) The AAN shall provide sufficient isolation against emissions from an AE or load connected to the wired network port being assessed. The attenuation of the AAN, for common mode emissions originating from the AE, shall be such that the measured level of these

emissions at the measuring receiver input is at least 10 dB below the relevant emission limit.

The preferred minimum isolation is:

- 35 dB to 55 dB, increasing linearly with the logarithm of the frequency across the range 0,15 MHz to 1,5 MHz ;
- 55 dB across the range 1,5 MHz to 30 MHz

NOTE Isolation is the ratio of the common mode emission originating in an AE to that consequentially appearing at the EUT port of the AAN.

- c) The AAN shall meet the longitudinal conversion loss (LCL) requirements stated in Table C.2 from 0,15 MHz to 30 MHz. Actual LCL values to simulate different cables are defined in Table C.2.

Table C.2 – LCL values

Cable category	LCL dB	Tolerance
3 (or better)	$L_{LCL}(\text{dB}) = 55 - 10\lg \left[1 + \left(\frac{f}{5} \right)^2 \right]$	±3 dB
5 (or better)	$L_{LCL}(\text{dB}) = 65 - 10\lg \left[1 + \left(\frac{f}{5} \right)^2 \right]$	±3 dB for $f < 2$ MHz -3 dB/+4,5 dB for f between 2 MHz and 30 MHz
6 (or better)	$L_{LCL}(\text{dB}) = 75 - 10\lg \left[1 + \left(\frac{f}{5} \right)^2 \right]$	±3 dB for $f < 2$ MHz -3 dB/+6 dB for f between 2 MHz and 30 MHz
Coaxial	n/a	n/a

NOTE 1 f has the units of MHz in the above formulas.

NOTE 2 These LCL values are approximations of the LCL values of typical unscreened balanced cables in representative environments. The specification for category 3 is considered representative of the LCL values of typical telecommunication copper access networks.

- d) The insertion loss or other deterioration of the signal quality in the wanted signal frequency band caused by the presence of the AAN shall not significantly affect the normal operation of the EUT.
- e) The AAN voltage division factor (V_{vdf}) shall be within ±1 dB of the nominal value across the frequency range 0,15 MHz to 30 MHz. The AAN voltage division factor is calculated as follows:

$$V_{\text{vdf}} = 20\lg \left| \frac{V_{\text{cm}}}{V_{\text{mp}}} \right| \text{ dB}$$

where

V_{cm} is the common mode voltage appearing across the common mode impedance presented to the EUT by the AAN; and,

V_{mp} is the resulting receiver voltage measured directly at the voltage measurement port of the AAN.

The voltage division factor shall be added to the measured voltage measured by the receiver directly at the voltage measurement port of the AAN and the result compared with the voltage limits in Table A.11 or Table A.12 as applicable.

C.4.1.3 Selection of AAN for unscreened balanced multi-pair cables

The type of AAN is selected according to the number of pairs physically in the cable excluding any pairs which do not have a galvanic connection to any part of the EUT, including ground.

The AAN described in Figure G.4 to Figure G.7 are only appropriate for use where there are no unconnected pairs in the cable. The AANs shown in Figure G.1 to Figure G.3 are suited to any situation, including those where the use of some of the pairs is unknown, or some pairs are known to be unconnected.

C.4.1.4 Current probe characteristics

The current probe shall have a uniform frequency response without resonances within the frequency range of interest. It shall be capable of operating without saturation effects caused by the operating currents in the primary winding.

The insertion impedance of the current probe shall not exceed 1 Ω . See 5.1 of CISPR 16-1-2:2003/ AMD 1:2004/ AMD 2:2006.

C.4.1.5 Characteristics of the CVP

The CVP defined in 5.2.2 of CISPR 16-1-2:2003/ AMD 1:2004/ AMD 2:2006 shall be used.

C.4.1.6 Measurements at wired network ports, antenna ports and optical fibre cables having metallic screens or strength members

C.4.1.6.1 Choice of measurement procedure

This clause describes the various measurement procedures that can be used to measure the common mode conducted emission of analogue/digital data ports. Depending on the cable type, different procedures may be used, each with its advantages and disadvantages. See G.2 and Table G.1.

C.4.1.6.2 Measurement procedure using an AAN

Measurement is made at wired network ports using AANs with longitudinal conversion losses as defined in Table C.2. The AAN for the cable category specified by the equipment documentation provided to the user shall be used. The level of emissions from the EUT shall not exceed the applicable limits of Annex A.

When emission voltage measurements are performed, the AAN shall provide a voltage measurement port suitable for connection to a measuring receiver while simultaneously satisfying the analogue/digital data port common mode termination impedance requirements.

For unscreened cables containing balanced pairs, an AAN conforming to C.4.1.2 shall be used. The LCL values of the AAN shall be within the tolerance given in Table C.2 for an AAN appropriate to the cable category connected to the EUT.

The procedure shall be as follows:

- arrange the EUT, local AE and associated cabling (examples are given Annex D);
- measure the voltage at the measurement port of the AAN;
- correct the measured voltage by adding the AAN voltage division factor (V_{vdf}) defined in C.4.1.2 e);
- compare the corrected voltage with the limit.

C.4.1.6.3 Measurement procedure using a 150 Ω load connected to the outside surface of the cable screen

This procedure can be used for all types of coaxial cables, screened multi-pair cables or optical fibre cables having metallic screens or strength members.

The procedure shall be follows:

- Arrange the EUT, local AE and associated cabling, generally as shown in Figure D.4 or Figure D.5, replacing the CVP in Figure D.4 by a 150 Ω adaptor. The current probe to EUT horizontal distance may be increased to 0,8 m. Alternatively in Figure D.5, the AAN shall be replaced by the 150 Ω adaptor/current probe combination.
- Break the external protective insulation (exposing the shield) and connect a 150 Ω resistor with a physical connection between the cable screen and the RGP. The 150 Ω resistor shall be $\leq 0,3$ m from the outside surface of the screen to ground. For further information refer to G.2.5.
- Insert a ferrite tube or clamp between the 150 Ω connection and the AE.
- Measure the current with a current probe and compare to the current limit. Use the procedure given in C.4.1.7 to measure the asymmetric common mode impedance from the 150 Ω resistor towards the AE, which should be much greater than 150 Ω so as not to affect the measurement at frequencies emitted by the EUT.
- The separation distance between the AE and the ground plane is not critical if the impedance of the ferrite is higher than that given in G.2.5. If this cannot be achieved, then the AE shall be placed at 0,4 m from a vertical or horizontal RGP, as defined for the EUT in Table D.2.

The voltage measurement may also be performed in parallel with the 150 Ω resistor with a high impedance probe. Alternatively, the measurement may be performed using a "150 Ω to 50 Ω adaptor" described in IEC 61000-4-6:2008 as the 150 Ω load and applying the appropriate correction factor (9,5 dB in case of the "150 Ω to 50 Ω adaptor").

C.4.1.6.4 Measurement procedure using a combination of current probe and CVP

As an AAN is not used in this procedure, the common mode impedance is not stabilized. The emissions from the EUT shall be measured using both the voltage and current probes and the measured levels compared with the voltage and the current limits respectively.

The procedure shall be as follows:

Arrange the EUT, local AE and associated cabling as defined in Annex D, either as shown in Figure D.4 or as shown in Figure D.5, replacing the AAN with the current probe/CVP combination.

A CMAD or similar device may be used between the AE and the current probe/CVP combination.

The AE shall be placed 0,4 m from a vertical or horizontal RGP, as defined for the EUT in Table D.2. Where appropriate, the EUT shall be powered using an AMN placed on the RGP. The AMN shall be placed $>0,10$ m from the nearest edge of the RGP. The EUT power cord shall be routed away from the cable used for the measurements to minimize coupling or crosstalk effects.

The current shall be measured with the current probe and the results compared with the current limits.

The voltage shall be measured with the CVP specified in C.4.1.5.

- The voltage measured shall be corrected at each frequency of interest as follows:
 - if the current margin with respect to the current limit is ≤ 6 dB, the actual current margin shall be subtracted from the measured voltage;
 - if the current margin with respect to the current limit is > 6 dB, 6 dB shall be subtracted from the measured voltage.
- The adjusted voltage shall be compared with the applicable voltage limit.

Both the measured current and the corrected voltage shall be below the applicable current and voltage limits at all frequencies for the EUT to be deemed compliant with this publication.

C.4.1.7 Measurement of cable, ferrite and AE common mode impedance

There are three possible procedures for the measurement of the CM impedance. The conditions for using these procedures are as follows:

Procedure 1 may only be used if the length of both the calibration loop circumference (defined in Figure C.6) and the AE loop circumference (defined in Figure C.7), is less than 1,25 m. This condition is necessary to minimise loop resonance(s) that could affect the impedance measurement and increase measurement uncertainty.

Procedure 2 or Procedure 3 shall be used if the length of either of the loops, defined in Figure C.6 and Figure C.7, is at least 1,25 m.

Procedure 1:

- The drive probe 50 Ω system shall be calibrated. See Figure C.6.
- Drive voltage (V_1) shall be applied from a signal generator into the drive probe and the resulting current (I_1) in the measurement probe shall be recorded.
- The cable used for the measurement from the EUT shall be disconnected and shall be shorted to ground at the EUT end.
- The same drive voltage (V_1) shall be applied to the cable with the same drive probe.
- The current shall be measured with the same measurement probe, and the asymmetrical common mode impedance of the cable, ferrite and AE combination shall be calculated by comparing the current reading (I_2) measured by the current probe with the previously measured current (I_1).

The common mode impedance is $50 \times I_1 \div I_2$. For example, if I_2 is half I_1 , then the common mode impedance is 100 Ω .

Procedure 2:

An impedance analyser shall be connected between the screen of the cable attached to the EUT port being assessed and the RGP, at the position where the 150 Ω resistor would be attached. The EUT shall not be powered during this measurement. The arrangements defined in C.4.1.6.3 apply. The measurement set-up is similar to that presented in Figure G.15.

Procedure 3:

Using a network analyser, a current probe and a CVP, the common mode voltage and current shall be measured. The ratio of the voltage to the current on the cable attached to the EUT port under test, as measured with the network analyser, defines the common mode impedance. The measurement set-up is similar to that presented in Figure G.15.

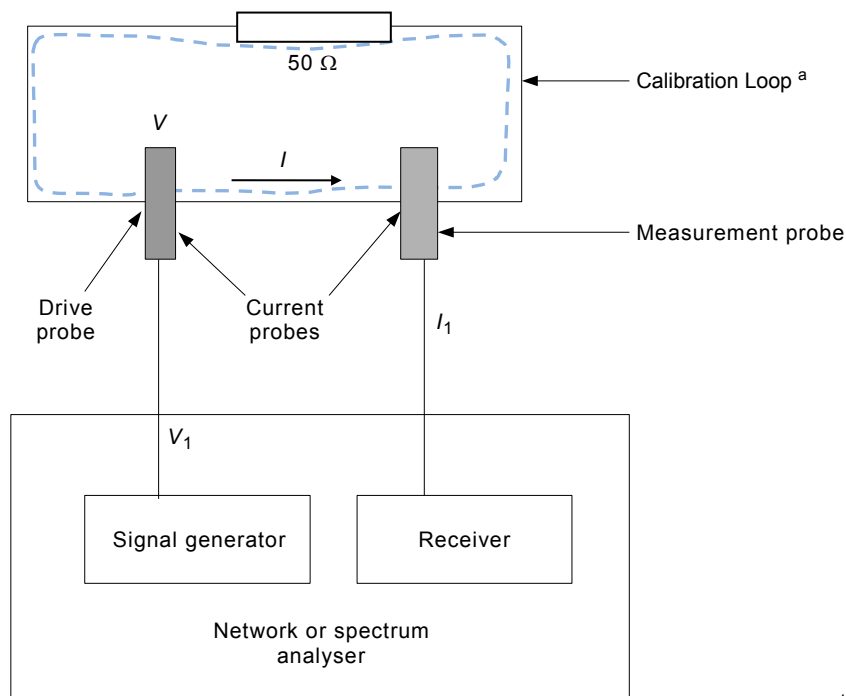

IEC

a Calibration loop is the circumference of the imaginary loop shown.

Figure C.6 – Calibration fixture

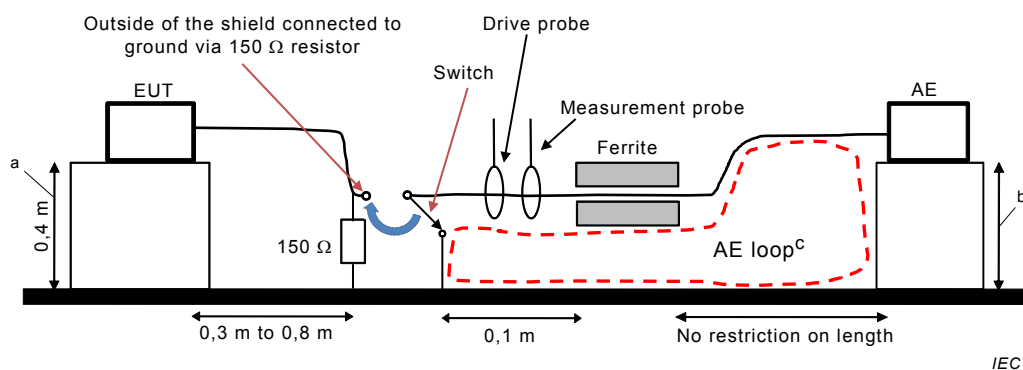

IEC

a distance to the reference ground plane (vertical or horizontal)

b distance to the reference ground plane is not critical

c AE loop is defined when the switch position connects the AE to ground, and is shown by the red dashed line

Figure C.7 – Arrangement for measuring impedance in accordance with C.4.1.7

C.4.2 Measurement of emission voltages at a TV/FM broadcast receiver tuner ports in the frequency range 30 MHz to 2,15 GHz

C.4.2.1 General

When measurements are performed at the TV/FM broadcast receiver tuner port of the EUT, a signal generator generating an unmodulated carrier shall be used to feed the receiver input with an RF signal at the tuned frequency of the EUT (see Annex B).

The output level of the signal generator shall be set to produce 60 dB(μ V) for FM reception, to 70 dB(μ V) for analogue TV reception, and to the levels specified in Table B.4 for digital TV reception. In each case the level specified is the voltage across the input impedance of the receiver (typically 75 Ω).

In order to determine the channel(s) of each reception mode to be used during formal measurement, an initial assessment using the scan mode of the broadcast receiver equipment may be used. Formal measurements may then be made using the channels that produced the highest emission for each reception mode (for example analog or digital).

C.4.2.2 Connection of AE (signal generator)

The TV/FM broadcast receiver tuner port of the EUT and the AE (signal generator) shall be connected to the input of the measurement device by means of coaxial cables and a resistive combining network (or another suitable device). The combining network or device used shall have a minimum attenuation of 6 dB between the AE and the measurement device. See Figure C.8.

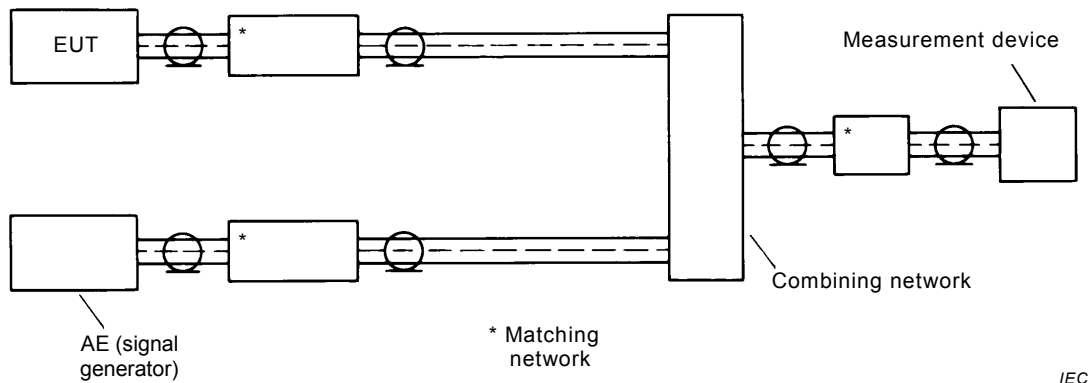

Figure C.8 – Circuit arrangement for measurement of emission voltages at TV/FM broadcast receiver tuner ports

The impedance as seen from the TV/FM broadcast receiver tuner port of the EUT shall be equal to the nominal antenna input impedance for which the port has been designed. The EUT shall be tuned to the wanted signal from the AE (signal generator). The emission level shall be measured across the relevant frequency range taking into account the attenuation between the EUT TV/FM broadcast receiver tuner port and the measurement device.

RF currents flowing from the chassis of the receiver to the outer surface of the screen of the coaxial cables should be prevented from penetrating into the coaxial system and thus causing erroneous measuring results, for example by means of ferrite tubes.

Attention should be given to possible overloading of the input stage of the measuring device due to the output signal of the AE (signal generator).

C.4.2.3 Presentation of the results

The results shall be expressed in terms of the emission voltage in dB(μ V). The specified input impedance of the TV/FM broadcast receiver tuner port shall be stated with the results.

C.4.3 Measurement of the wanted signal and emission voltage at RF modulator output ports, in the frequency range 30 MHz to 2,15 GHz

C.4.3.1 General

If an EUT has an RF modulator output port (for example video recorders, camcorders, decoders) additional measurements of the wanted signal level and emission voltage at its RF modulator output port shall be performed.

C.4.3.2 Measurement procedure

The RF modulator output port of the EUT is connected to the input of the measuring device by means of a coaxial cable and a matching network (if necessary) as shown in Figure C.9. The characteristic impedance of the cable shall be equal to the nominal output impedance of the EUT. The EUT shall produce an RF carrier modulated by a video signal defined in Annex B.

The RF output level shall be obtained by adding the insertion loss of the matching network to the indication of the measuring device (tuned to the video carrier frequency and its harmonics).

An initial assessment using the scan mode of the modulator may be used to determine the channel at which the modulator produces the highest emission level. This channel shall be used to perform the formal measurement.

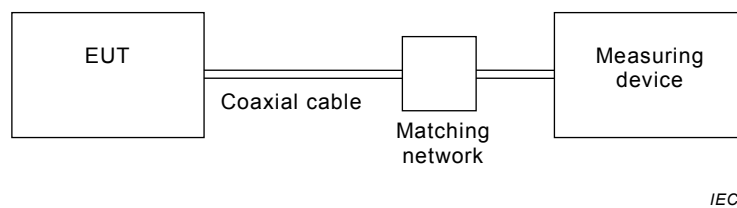

Figure C.9 – Circuit arrangement for the measurement of the wanted signal and emission voltage at the RF modulator output port of an EUT

C.4.4 Additional Normalized Site Attenuation (NSA) values

The procedure defined in CISPR 16-1-4:2010/AMD1:2012 and values presented in Table C.3 shall be used to perform NSA at the 5 m distance where this is needed.

Table C.3 – 5 m OATS/SAC NSA values

Polarization	Horizontal		Vertical	
D (m)	5	5	5	5
H_1 (m)	1 – 4	1 – 4	1 – 4	1 – 4
H_2 (m)	1	2	1	1,5
Frequency (MHz)	NSA (dB)			
30,00	20,7	15,6	11,4	12,0
35,00	18,2	13,3	10,1	10,7
40,00	16,0	11,4	8,9	9,6
45,00	14,1	9,8	7,9	8,6
50,00	12,4	8,5	7,1	7,8
60,00	9,5	6,3	5,6	6,3
70,00	7,2	4,6	4,3	5,2
80,00	5,3	3,2	3,3	4,3
90,00	3,7	2,0	2,4	3,5
100,00	2,3	1,0	1,6	2,9
120,00	0,1	-0,7	0,3	2,1
140,00	-1,7	-2,1	-0,6	1,7
160,00	-3,1	-3,3	-1,3	1,0
180,00	-4,3	-4,4	-1,8	-1,0
200,00	-5,3	-5,3	-2,0	-2,6
250,00	-7,5	-6,7	-3,2	-5,5
300,00	-9,2	-8,5	-6,2	-7,5
400,00	-11,8	-11,2	-10,0	-10,5
500,00	-13,0	-13,3	-12,5	-12,6
600,00	-14,9	-14,9	-14,4	-13,5
700,00	-16,4	-16,1	-15,9	-15,1
800,00	-17,6	-17,3	-17,2	-16,5
900,00	-18,7	-18,4	-17,4	-17,6
1 000,00	-19,7	-19,3	-18,5	-18,6

These data apply to antennas that have at least 250 mm of RGP clearance when the centre of the antenna is 1 m above the RGP in vertical polarization.

D measurement distance
 H_1 height of the receiving antenna
 H_2 height of the transmitting antenna

Annex D (normative)

Arrangement of EUT, local AE and associated cabling

D.1 Overview

D.1.1 General

The intention of this publication is to measure the emissions from the EUT in a manner that is consistent with its typical arrangement and use. The measurement arrangement of the EUT, local AE and associated cabling shall be representative of normal practice.

The EUT shall be arranged in accordance with the requirements of Table D.1

Table D.1 – Measurement arrangements of EUT

Intended operational arrangement(s) of MME	Measurement arrangement	Remarks
Table-top only	Table-top	
Floor-standing only	Floor-standing	
Can be floor-standing or table-top	Table-top	
Rack mounted	In a rack or table-top	
Other, for example wall mounted, ceiling mounted, handheld, body worn	Table-top	With normal orientation If the equipment is designed to be mounted on a ceiling, the downward-facing portion of the EUT may be oriented facing upward.
If a physical hazard would be caused by testing the device on a table top, then it can be arranged as floor standing and the test report shall document the decision and justification.		

All cables that are considered part of the EUT shall be arranged as for normal use subject to length restrictions given in Table D.2 and subject to the requirement to minimise the size of the arrangement. For example, the keyboard and mouse of a personal computer set-up shall be placed in front of the monitor.

The following arrangements may be used to limit the effects of adverse AE emissions or to reduce measurement time, as long as the arrangement can be shown not to reduce the emissions measured from the EUT:

- placing AE below the RGP;
- placing AE below the test volume of a FAR; or,
- placing AE outside the measurement area when it is normally located distant from the EUT.

An EUT intended for rack mounting may be arranged in a rack or as table-top equipment. An EUT that can be used in both floor standing and table-top configurations, or both floor standing and wall mounted configurations, shall be assessed in a table-top arrangement. However, if the usual installation is floor standing, then that arrangement shall be used.

The type and construction of cables used in the measurement set-up shall be consistent with normal or typical use. Cables with mitigation features (for example, screening, tighter/more twists per length, ferrite beads) shall only be used if it is the intention that all deployments will use these features. If the cable(s) have mitigation features, this detail shall be specified in the

test report. Manufacturer-supplied or commercially available cabling shall be used, as specified in the installation manual or user manual.

Cables connecting to AE located outside the measurement area shall drop directly to, but be insulated from, the RGP (or turntable where applicable), and then be routed directly to the place where they leave the test site. The thickness of the insulation shall not be more than 150 mm. However, cables which would normally be bonded to ground should be bonded to the RGP in accordance with normal practice or the manufacturer's recommendation.

During conducted emission measurements on analogue/digital data ports, the cable between the EUT and the measurement device or probe shall be as short as possible and satisfy the requirements given in Table D.2.

Where practical, any excessive length in cables shall be bundled non-inductively, at the mid point between the EUT and the AMN or AAN, for the conducted emission measurement. The bundle length shall be less than 0,4 m to satisfy the distances given in Table D.2.

Non-inductive bundling means that the cable is shortened by overlapping loops arranged with alternate end loops wound in opposite directions using the minimum practicable bend radius. Where bundling cannot be achieved, coiling of the cables shall be avoided.

The effective length of all loop-back cables not routed overhead shall be longer than 2 m. Where possible, loop-back cables shall be arranged so that outgoing line is not closely coupled to the return.

Where possible, the effective length of mains cables shall be $1 \text{ m} \pm 0,1 \text{ m}$.

Cable length is the distance between cable connector ends, excluding any protruding pins, when the cable is laid straight. The effective cable length, is the distance between cable connector ends, excluding any protruding pins, when the cable includes one or more bundles. The effective cable length will be shorter than the actual length if the cable has been bundled.

Loads and/or devices simulating typical operating conditions shall be connected to at least one of each type of interface port of the EUT. If loading (or terminating) with a device of actual usage is not feasible, the port should preferably be loaded with a simulator. Where these options are not practical the port shall be loaded by the application of a typical impedance considering both the common and differential modes. These loads and/or devices shall be connected via a cable if this represents normal usage.

Where there are multiple ports of the same type the manufacturer shall determine whether to load these additional ports, considering:

- maximisation of the emission levels, for example, when adding additional cables does not significantly affect the emission level (for example varies less than 2 dB), it can be assumed a maximum has occurred;
- reproducibility;
- achievement of a representative configuration having regard to other requirements in this clause.

For example, additional cables with or without terminations may be connected to the EUT ports. This process may also be applied to establishing the number of similar elements (plug-in modules, internal memory, and so forth) within the EUT.

Where the EUT has more than one analogue/digital data port, ports shall be included in the measurement arrangement as follows:

- if there are multiple similar ports on the same card or module type, then it is acceptable to assess one typical port,

- where there are ports of the same type on different card or module types, then it is acceptable to assess one typical port on each card or module types.

The test report shall identify the ports assessed.

An EUT which requires a dedicated ground connection shall be bonded to the RGP or to the chamber wall or chamber floor in case of a FAR, with a grounding connection that is similar to that used in practice.

When making measurements in a FAR, any measurements of height are referenced to the bottom of the test volume.

NOTE When testing in a FAR, measurements of height are made to the top surface of the turntable or the top of the floor absorber when the floor absorber extends above the turntable.

Any antenna masts and supporting floors shall be in place during site validation. All other relevant conditions of Table D.1 and Table D.2 apply. For example, unpainted expanded polystyrene may be used as a supporting platform above the turntable.

See Figure D.1 through Figure D.10 for examples of arrangements.

Requirements for EUT spacing and distances are given in Table D.2.

Table D.2 – Arrangement spacing, distances and tolerances

Table Clause	Element	Spacing/ Distances	Tolerance (\pm)	Measurement
D2.1	Spacing between any two elements on the measurement table	$\geq 0,1$ m	10 %	Both
D2.2	Spacing between any two elements where one or more of the elements are not on a table-top	Typical	n/a	Both
D2.3	Minimum distance between the rack (or cabinet) containing the EUT and the vertically rising cabling which would normally leave the measurement facility	0,2 m	10 %	Both
D2.4	Spacing between AMN and EUT	0,8 m	10 %	Conducted
D2.5	Spacing between AMN and local AE	$\geq 0,8$ m	10 %	Both
D2.6	Spacing between AAN and EUT	0,8 m	10 %	Conducted
D2.7	Horizontal spacing between EUT and current probe (or 150 Ω resistor) (See ^b) Spacing between current probe and 150 Ω resistor Spacing between 150 Ω resistor and optional ferrites (CMAD)	0,3 m to 0,8 m 0,1 m 0,1 m	10 %	C.4.1.6.3
D2.8	Horizontal spacing between EUT and current probe (See ^b) Spacing between current probe and CVP Spacing between 150 Ω resistor and optional ferrites (CMAD)	0,3 m 0,1 m 0,1 m	10 %	C.4.1.6.4
	Space between the cable under test and the RGP.	0,04 m	$\pm 0,01$	
D2.9	Spacing between AAN and local AE	$\geq 0,8$ m	n/a	Conducted
D2.10	Measurement distance when testing frequencies up to 1 GHz. See Table A.2, Table A.4, Table A.6 and Table A.7	3 m to 10 m	$\pm 0,1$ m	Radiated
D2.11	Measurement distance when testing frequencies above 1 GHz. See Table A.3, Table A.5 and Table A.7	1 m to 10 m	$\pm 0,1$ m	Radiated
D2.12	Spacing between: EUT, local AE and associated cabling; and metal surfaces other than the RGP This spacing does not apply when a combination of table-top and floor-standing equipment is measured. In this case the table-top EUT may be 0,4 m from the vertical RGP as shown in Figure D.7.	$\geq 0,8$ m	10 %	Conducted
D2.13	Thickness of insulation between floor standing EUT, local AE and associated cabling and the RGP	$\leq 0,15$ m	10 %	Both
D2.14	Height to the top of table for radiated measurements	0,8 m	$\pm 0,01$ m	Radiated
D2.15	Height to the top of table for conducted measurements	0,8 m or 0,4 m	$\pm 0,01$ m	Conducted
D2.16	Spacing between table-top EUT, local AE and associated cabling and the RGP For measuring analogue/digital data ports, the line under test shall be kept 0,4 m distant from the RGP for as long as possible before being run to the termination point. For testing using C.4.1.6.3 this also includes the cable from the measurement device to the AE. The section of cable running to and from the termination point shall be exempt from the spacing to the RGP requirement given here.	0,4 m	10 %	Conducted
D2.17	Spacing between: table-top EUT/AE cables or bundled EUT/AE cables draped over the back of the table; and the RGP This may be achieved by a non-conductive support.	0,4 m above the RGP	10 %	Both
D2.18	Height of the cables connecting table-top and floor standing parts	See ^a	10 %	Both

^a Lowest of: 0,4 m; or connector height

^b Where the test arrangement is 0,4 m from a vertical RGP the horizontal spacing is from the projection of the EUT onto the vertical RGP, to the current probe. See Figure D.4.

Measurement types have the following meaning:

- Conducted = All types of conducted measurements
- Radiated = All types of radiated measurements
- Both = All types of conducted measurements and all types of radiated measurements

Where manufacturer-provided cables have to be used and are too short to meet the requirements of this table, the equipment shall be arranged to be as close to the requirements of this table as is reasonably practical and the actual arrangement shall be described in the test report.

The EUT, local AE and associated cabling shall be arranged in the most compact practical arrangement while respecting typical spacing and the requirements of this table.

Where the EUT is a module as defined in Figure 2, the distances specified relative to the EUT are measured to the surface of the

host.

Where the EUT is rack mounted, the distances specified relative to the EUT are measured to the surface of the rack.

Tolerance value aligned with the CISPR 16 series.

D.1.2 Table-top arrangement

The following specific arrangements apply.

Equipment, including the power supply, intended for table-top use shall be placed on a non-conductive table of sufficient size to hold the EUT, local AE and associated cabling. Where practical, the rear of the EUT should be flush with the rear of the table.

For radiated measurements the table shall be made of a material with a dielectric constant which minimises the impact on the results, for example, by the use of unpainted expanded polystyrene. Subclause 5.5.2 of CISPR 16-1-4:2010/AMD1:2012 describes a measurement to help ensure that the dielectric qualities of the material used for construction of the table are appropriate.

The arrangement of external power supply units (including AC/DC power converters) shall meet the requirements of Table D.2. Where possible, cables that connect between modules or units shall hang over the back of the table. If a cable hangs closer than 0,4 m from the horizontal RGP (or floor), the excess shall be folded at the cable centre into a bundle no longer than 0,4 m, such that the bundle is 0,4 m above the horizontal RGP.

If the mains port input cable is less than 0,8 m long, (including power supplies integrated in the mains plug) an extension cable shall be used such that the external power supply unit is placed on the measurement table. The extension cable shall have similar characteristics to the mains cable (including the number of conductors and the presence of ground connection). The extension cable shall be treated as part of the mains cable.

Power supply output cables shall be treated as inter-unit cables.

Equipment may be stacked if this is a normal arrangement for this equipment.

Example measurement arrangements are given in Figure D.1 to Figure D.5 and Figure D.8.

D.1.3 Floor standing arrangement

Where cable routing is specified by the manufacturer, this routing shall be used.

Where the inter-unit cabling is typically routed overhead, it shall be routed vertically to an overhead support. Overhead inter-unit cables shall rise from the first unit up to the support, run along the support, and drop down into the other unit. Overhead exit cables shall rise from the first unit up to the support, run along the support to a specified distance, drape down to the RGP, and route out of the facility to remote AE. Excess cable shall be bundled non-inductively on, but separated from, the RGP (respecting separation distances as defined in Table D.2).

Mains cabling shall drape vertically to (but be insulated from) the horizontal RGP.

The EUT shall be insulated (by insulation of maximum thickness of 150 mm) from the horizontal reference ground plane. If the equipment requires a dedicated ground connection, this shall be provided and bonded to the RGP.

Examples are given in Figure D.6 and Figure D.9.

D.1.4 Combinations of table-top and floor standing EUT arrangement

The following specific arrangements apply.

For the assessment of a combination of table-top and floor standing EUT, two RGPs may be required. The horizontal plane is always the RGP for the floor standing equipment while the RGP for the table-top equipment during conducted emission measurements may be either horizontal or vertical. The inter-unit cables between a table-top unit and a floor standing unit which are long enough to drape on the horizontal RGP shall be non-inductively bundled (or if too short or stiff for bundling, arranged but not-coiled) and placed on the table or supported at 0,4 m or at the height of the lowest cable entry point if this is below 0,4 m.

Examples of general arrangements are given in Figure D.7 and Figure D.10.

D.1.5 Arrangements for radiated measurement in a FAR

Where necessary, an access hole should be provided in the centre of the turntable to facilitate routing of cables.

Mains power outlets may be placed on the surface of the turntable (or supporting element), if the site validation requirements for the chamber can be met in this configuration.

The arrangement of the EUT and local AE shall be identical to those used for measurements using a OATS/SAC/FSOATS except for cables that leave the test area. These cables shall be routed horizontally with a minimum exposed length of 0,8 m, before being routed vertically with a minimum of exposed length of 0,8 m, to the bottom of the test volume (See Figure D.12). They shall then be routed to the centre of the turntable where, if possible the cables shall drape vertically downward. The cables shall then leave the chamber by the shortest possible route to minimise any impact. Where the cables are shorter than 1,6 m, as defined by the manufacturer, then the horizontal component shall be as close to 0,8 m as possible.

Example measurement arrangements are given in Figure D.11 and Figure D.12.

D.2 MME-related conditions for conducted emission measurement

D.2.1 General

During measurements of conducted emissions, any required dedicated ground connection of the EUT shall be made to the reference point of the AMN. Where not otherwise provided or specified by the manufacturer, this ground connection shall be of the same length as the mains port cable and run parallel to the mains port cable at a separation distance of not more than 0,1 m.

“Coaxial” broadcast receiver tuner ports shall be connected to an AAN (or a CDN as defined in IEC 61000-4-6) that provides a 150 Ω common mode termination to ground and is bonded to the RGP.

In addition to the general principles given above the following requirements apply.

The mains cable of the unit being assessed shall be connected to one AMN. All other units of the EUT and AE shall be connected to a second (or multiple) AMN(s). It is acceptable to connect these other equipments to an AMN via extension cables that include one or multiple socket outlets. Where additional socket outlets are needed, the extension shall be as short as practical. All AMNs shall be bonded to a RGP.

For AMNs mounted below the RGP an extension cable may be used. The AMN specification shall be met at the connection point for the EUT (the end of the extension cable or power strip) with at least 0,8 m spacing between the EUT and the connection point on the extension cable.

Where the EUT is a collection of equipment with multiple units, each having its own power cable, the point of connection for the AMN is determined by the following rules:

- for an EUT that has several modules, each with its own power cable (however terminated) and for which the manufacturer provides a power strip (multi-socket mains splitter) with a single power cable for connection to the external power source, a single measurement shall be performed at the mains input to that power cable;
- power cables or terminals which are not specified by the manufacturer to be connected via a host unit shall be measured separately;
- power cables or field wiring terminals (mains input terminals) which are specified by the manufacturer to be connected via a host unit or other power-supplying equipment shall be connected as described by the manufacturer;
- where a special connection is specified, the necessary hardware to effect the connection shall be supplied by the manufacturer for the purpose of this measurement.

In all other cases the conducted emissions on each individual EUT with its own power cable that is terminated in a power supply plug of a standard design (IEC TR 60083 for example) shall be measured separately.

Any AAN used during conducted emission measurements shall be selected and configured to be representative of the network in which the EUT is intended to operate. All ports of the AAN shall be correctly terminated in accordance with D.1. Where the 1 m requirement cannot be achieved, because of the position of the power input port/wired network port, then the effective length shall be as short as possible. In the case of EUTs including floor standing equipment the cable connecting the analogue/digital data port to the AAN may be positioned perpendicular to the EUT for a distance between of 0,3 m and 0,8 m then drop vertically to (but be insulated from) the horizontal RGP before being extended to the AAN. In these cases any bundling may be located on (but be insulated from) the ground plane

D.2.2 Specific conditions for table-top equipment

The RGP shall have a minimum size of 2 m by 2 m and shall extend a minimum of 0,5 m beyond the EUT, local AE and associated cabling in all directions.

Alternative 1: The measurement shall be performed using a vertical RGP. The rear of the EUT, local AE and associated cabling shall be 0,4 m from the vertical RGP. All ground planes in use shall be bonded together. AMN(s) and AAN(s) in use shall be bonded to either the vertical RGP or other metal planes bonded to it.

The portions of signal cables that hang over the rear of the table shall be positioned at a distance of 0,4 m from the vertical RGP and no less than 0,4 m from any horizontal RGP bonded to the vertical RGP. If necessary, maintain the separations using a fixture made of non-conductive material with an appropriate dielectric constant.

An example of the measurement arrangement is given in Figure D.2.

Alternative 2: The measurement shall be performed with a horizontal RGP. The EUT, local AE and associated cabling shall nominally be spaced 0,4 m above the horizontal RGP.

Example measurement arrangements are given in Figure D.3 and Figure D.5.

D.2.3 Specific requirements for floor standing equipment

If conducted emission measurements are undertaken within a SAC, the EUT, local AE and associated cabling shall be configured as defined in D.2.1. whilst meeting the general principles given in D.1.1. The AE cable routing shall be overhead if the EUT is designed for this configuration. Example measurement arrangements are given in Figure D.6.

D.2.4 Specific requirements for combined table-top and floor standing equipment

The configuration for conducted emission measurements shall be as defined in D.2.1 whilst meeting the general principles given in D.1.1.

The table-top equipment shall be assessed using alternative 1 or alternative 2 in D.2.2. The floor standing equipment shall be assessed on a horizontal RGP. If a vertical RGP is used for the table-top equipment, care shall be taken that the floor standing equipment is at least 0,8 m from the vertical RGP. This may require that the spacing between the table-top equipment and floor standing equipment be set at a small and convenient distance.

Example measurement arrangements are given in Figure D.7.

D.3 MME-related requirements for radiated measurement

D.3.1 General

Unless some other configuration is typical of normal use, or specified by the manufacturer, mains cables shall drop directly to the RGP before being routed to the mains power outlet. This outlet should not protrude above the RGP. If the outlet has a metal case, it shall be bonded to the RGP. If the mains outlet has a protective earth, it shall be bonded to the RGP. If used, the AMN shall be installed under the RGP.

D.3.2 Requirements for table-top equipment

Excess length of cables shall only be included in the arrangement to represent normal installation and shall be bundled in line with D.1.1. An example measurement arrangement is given in Figure D.8.

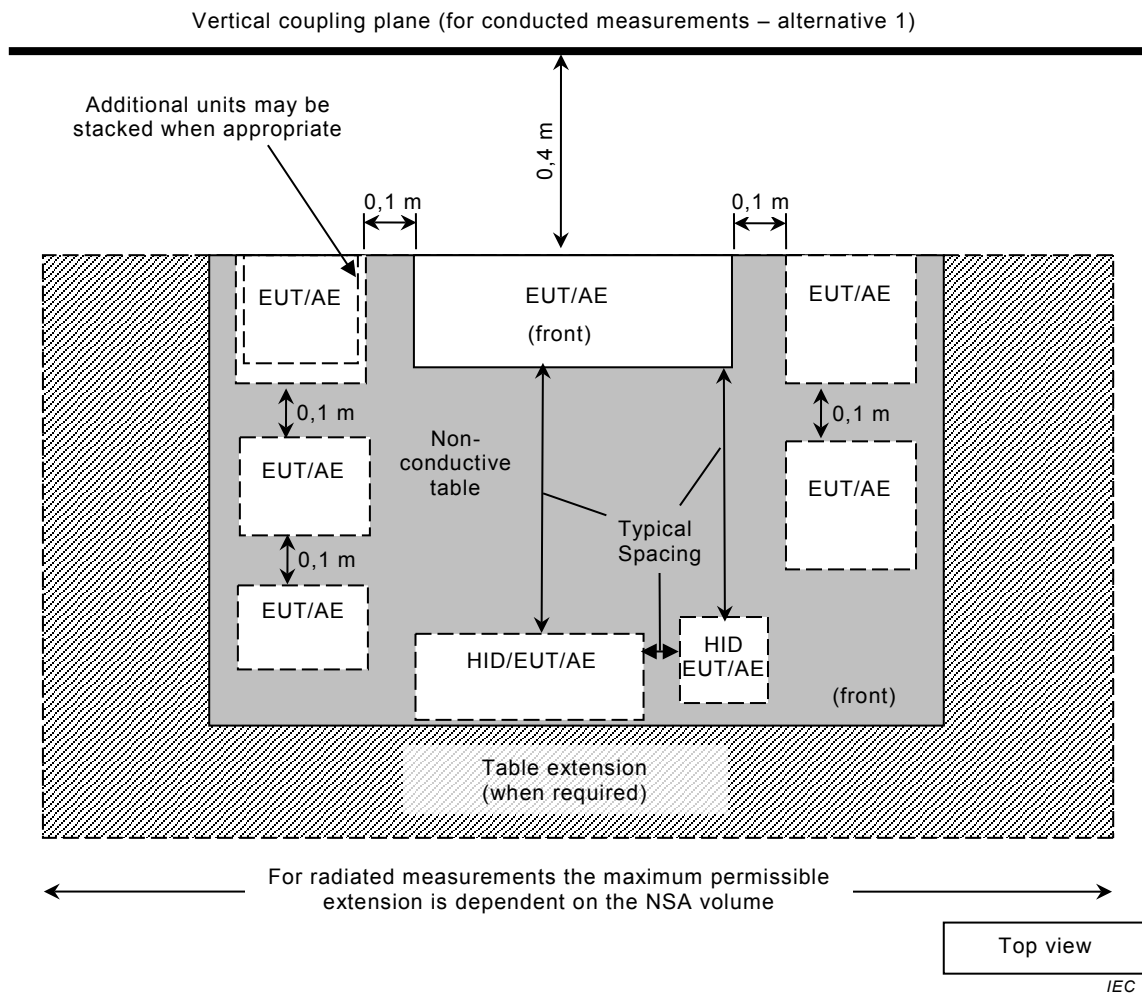
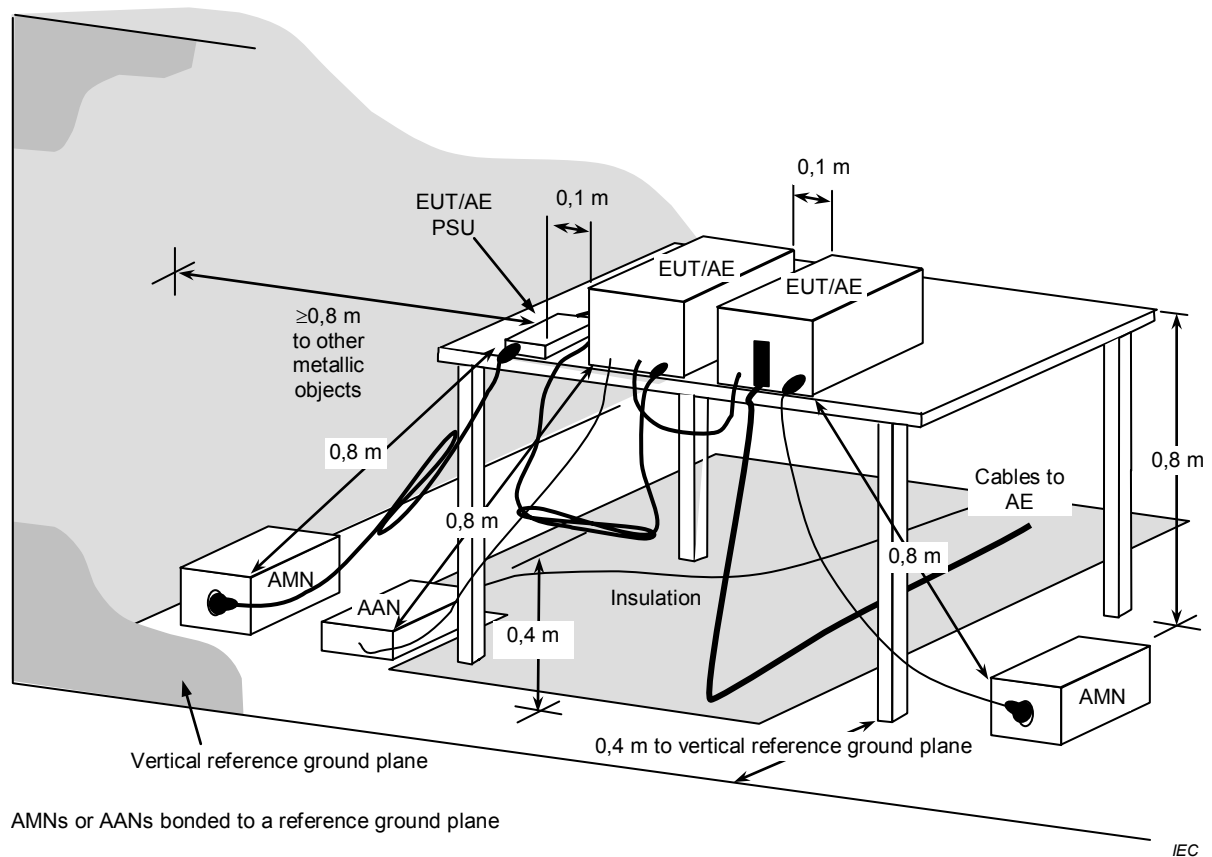
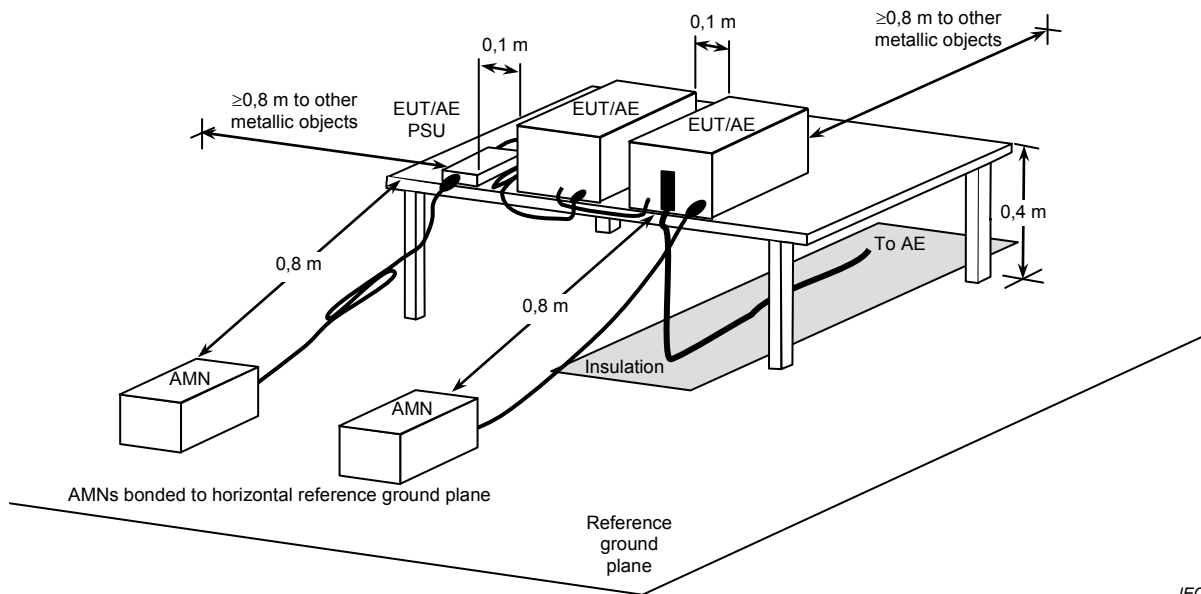

Figure D.1 – Example measurement arrangement for table-top EUT (conducted and radiated emission) (top view)



The 0,8 m distance specified between EUT/AE/PSU and AMN/AAN, is applicable only to the EUT being measured. If the device is AE then it shall be $\geq 0,8$ m.

**Figure D.2 – Example measurement arrangement for table-top EUT
(conducted emission measurement – alternative 1)**



The 0,8 m distance specified between EUT/local AE/PSU and AMN, is applicable only to the EUT being measured. If the device is AE then it shall be $\geq 0,8$ m.

Figure D.3 – Example measurement arrangement for table-top EUT (conducted emission measurement – alternative 2)

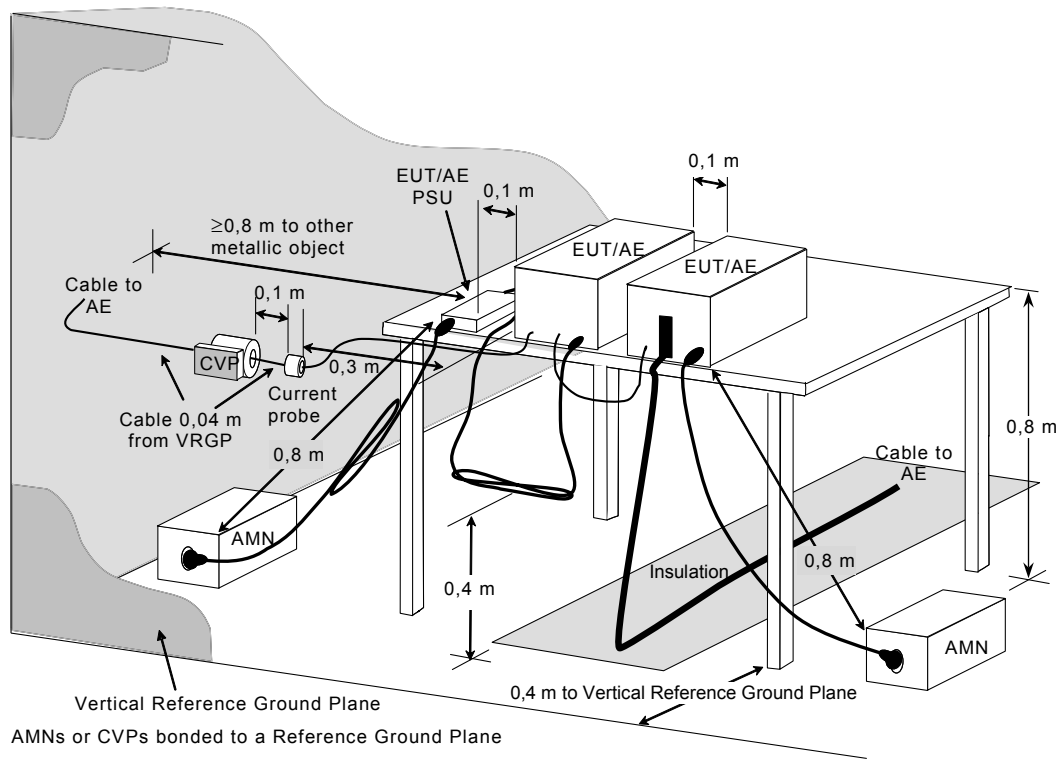

The 0,8 m distance specified between EUT/local AE/PSU and AMN/AAN, is applicable only to the EUT being measured. If the device is AE then it shall be $\geq 0,8$ m.

The cable under test shall be positioned 0,04 m from the vertical RGP and run at this position between the EUT and AE. This restriction does not apply to the section of the cable passing through the voltage probe.

Figure D.4 – Example measurement arrangement for table-top EUT measuring in accordance with C.4.1.6.4

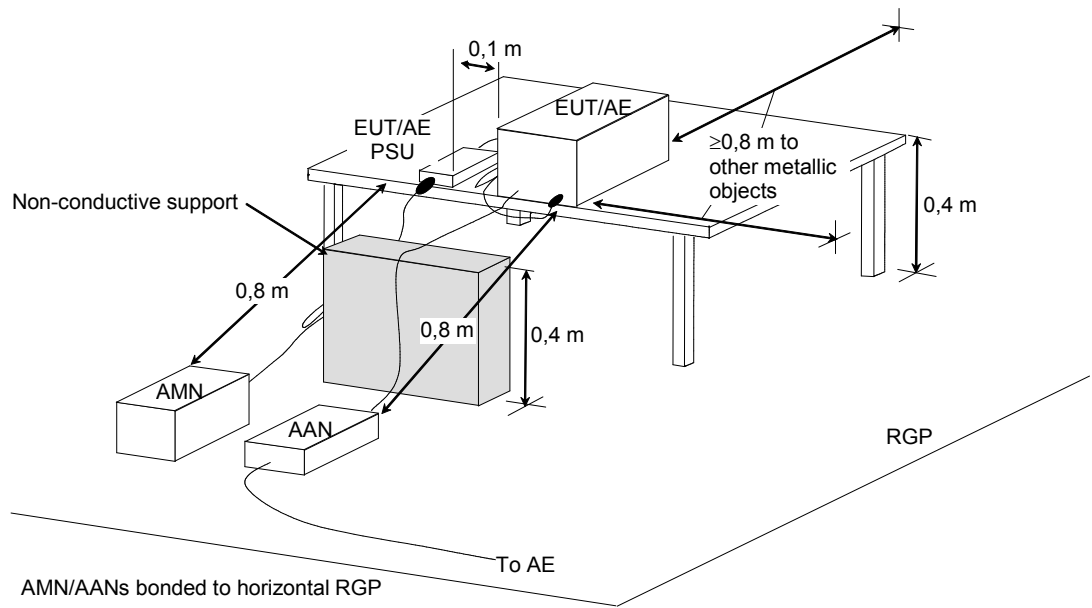

The 0,8 m distance specified between EUT/local AE/PSU and AMN/AAN, is applicable only to the EUT being measured. If the device is AE then it shall be $\geq 0,8$ m.

Figure D.5 – Example measurement arrangement for table-top EUT (conducted emission measurement – alternative 2, showing AAN position)

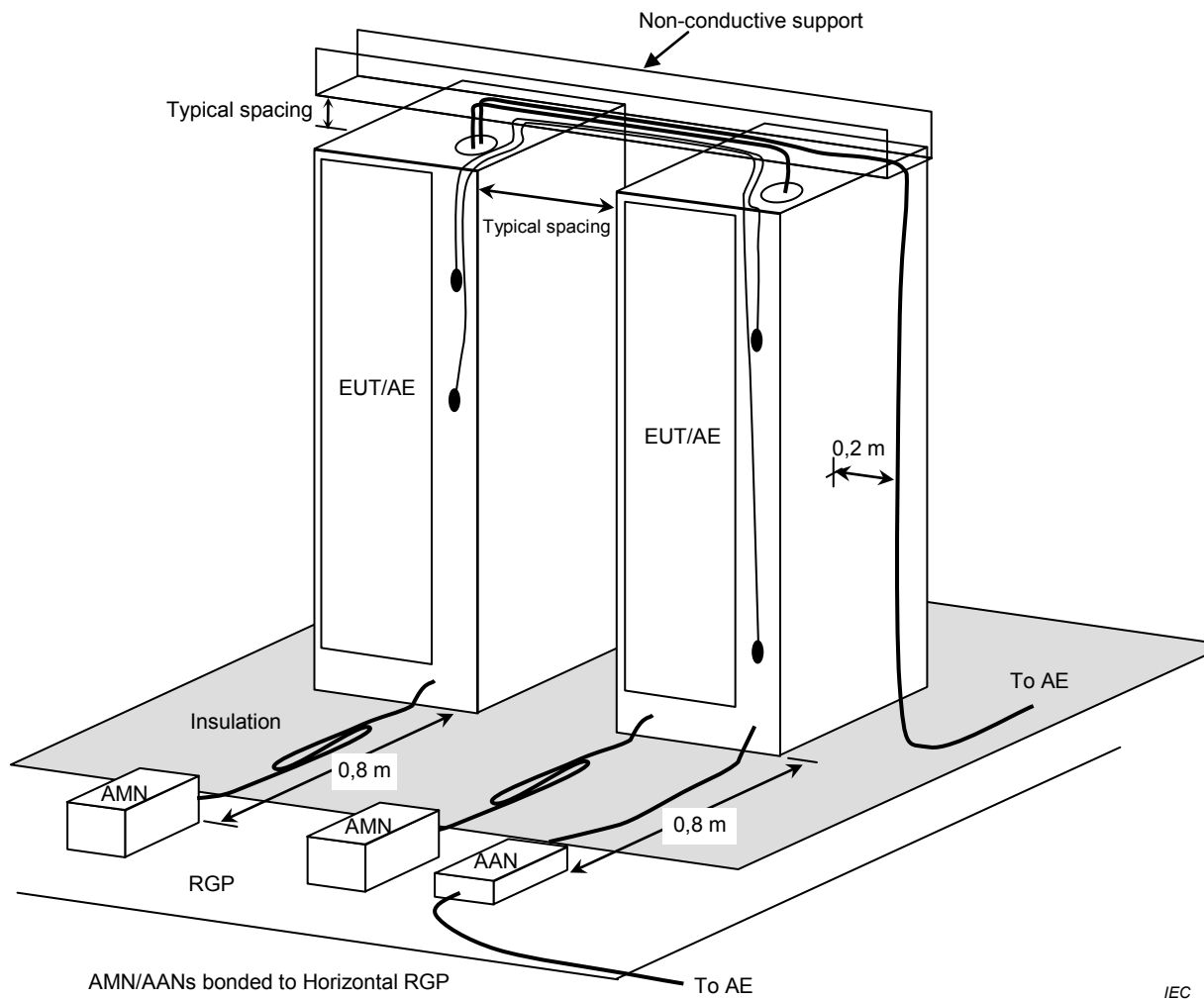

IEC

Figure D.6 – Example measurement arrangement for floor standing EUT (conducted emission measurement)

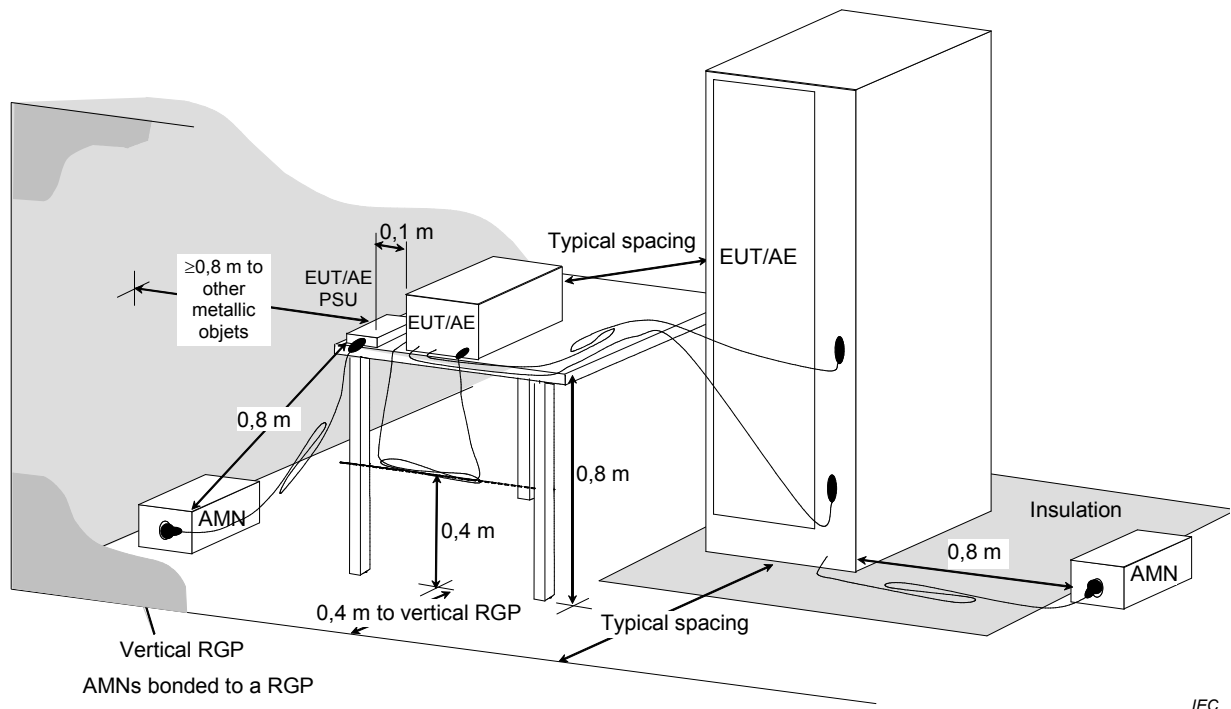

IEC

The 0,8 m distance specified between EUT/local AE/PSU and AMN, is applicable only to the EUT being measured. If the device is AE then it shall be $\geq 0,8$ m.

Figure D.7 – Example measurement arrangement for combinations of EUT (conducted emission measurement)

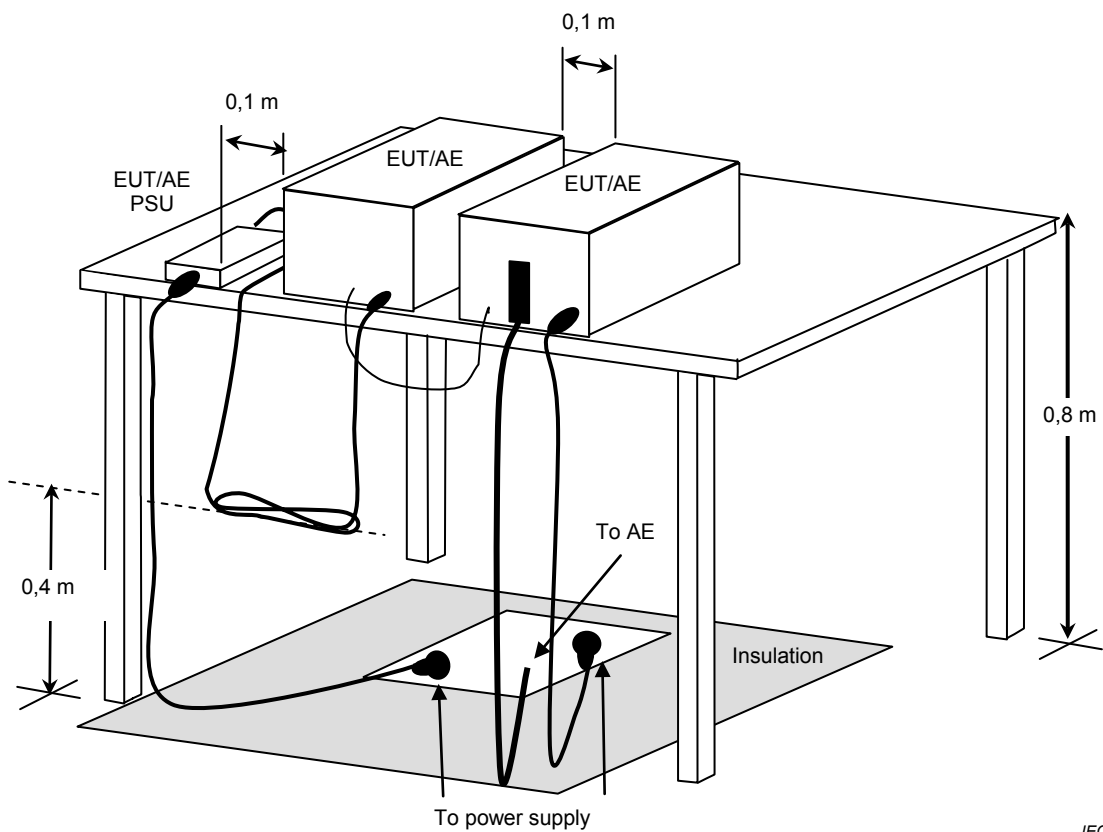

IEC

Figure D.8 – Example measurement arrangement for table-top EUT (radiated emission measurement)

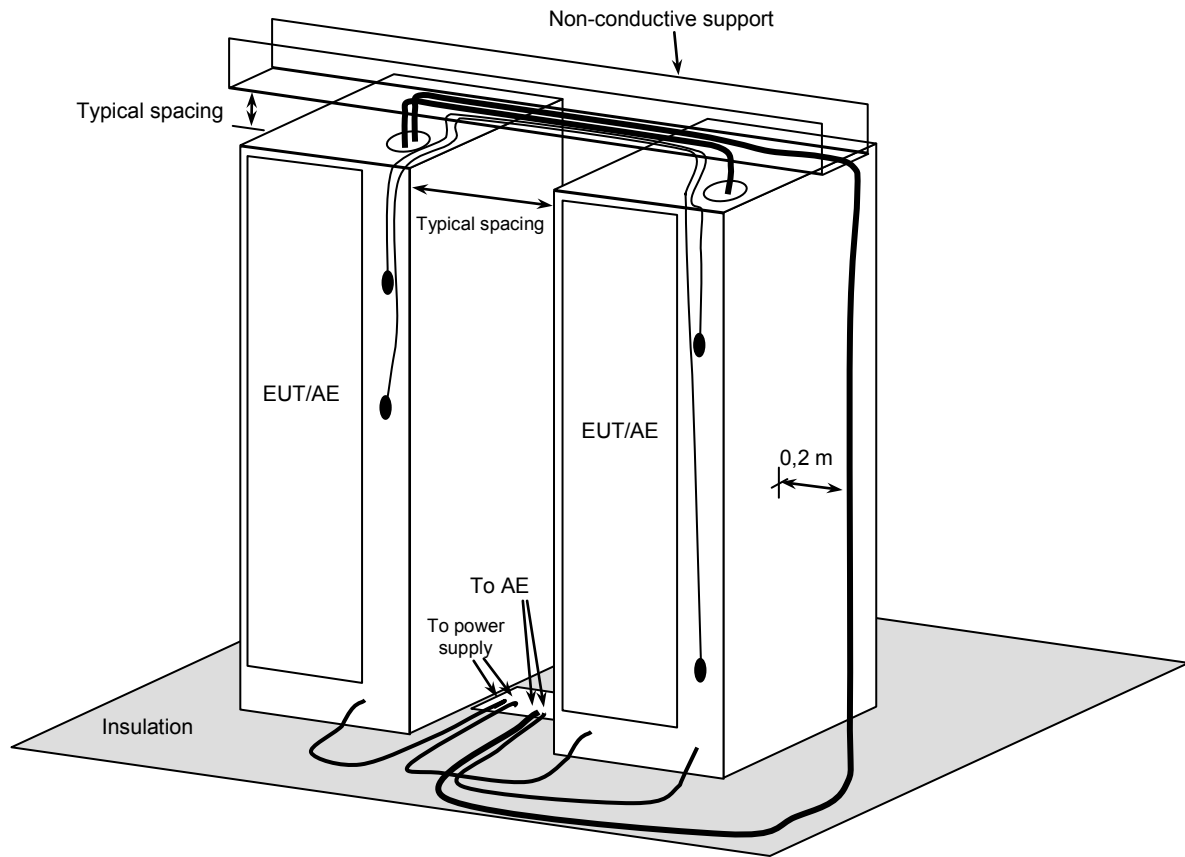

IEC

Figure D.9 – Example measurement arrangement for floor standing EUT (radiated emission measurement)

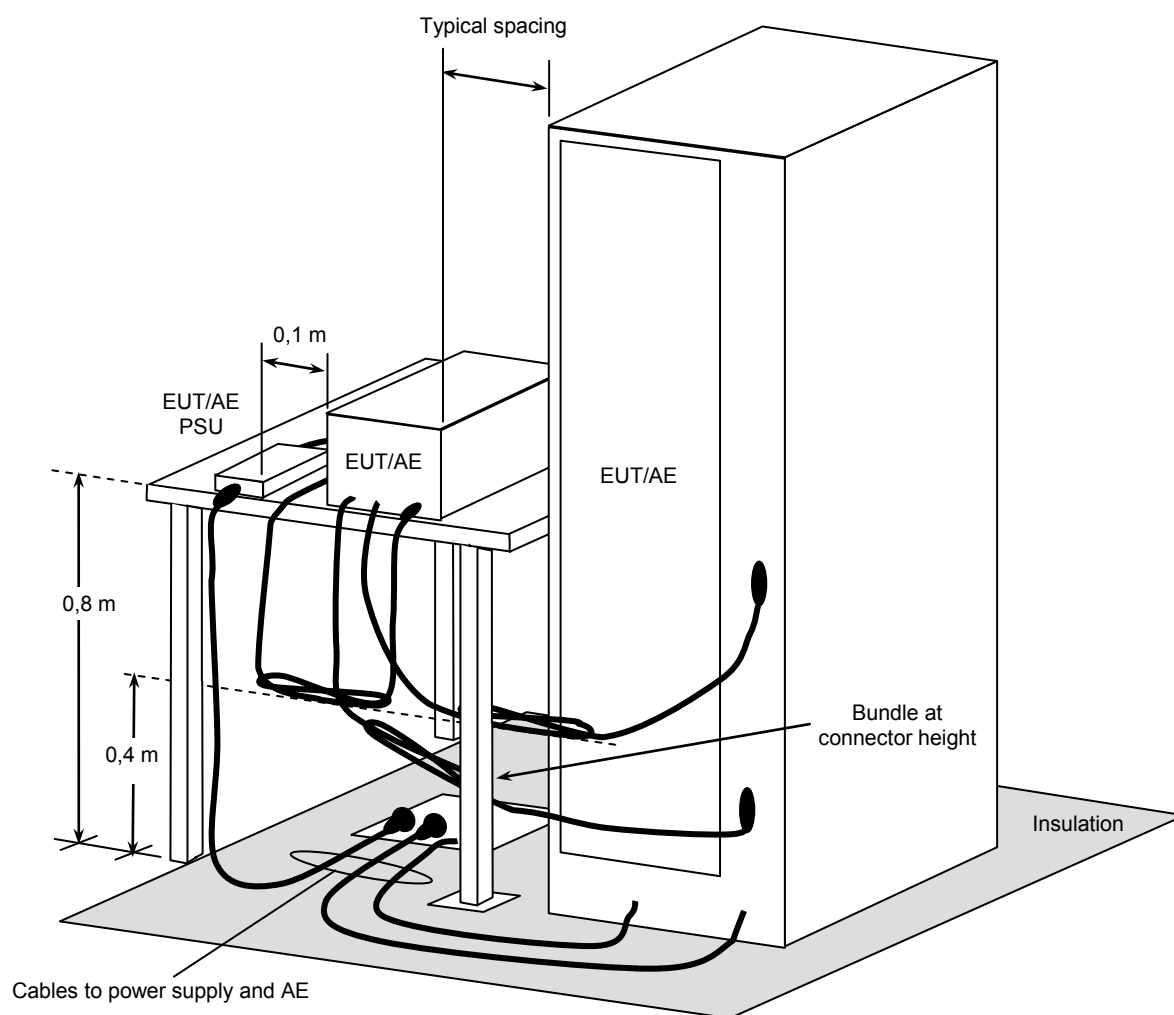

IEC

Figure D.10 – Example measurement arrangement for combinations of EUT (radiated emission measurement)

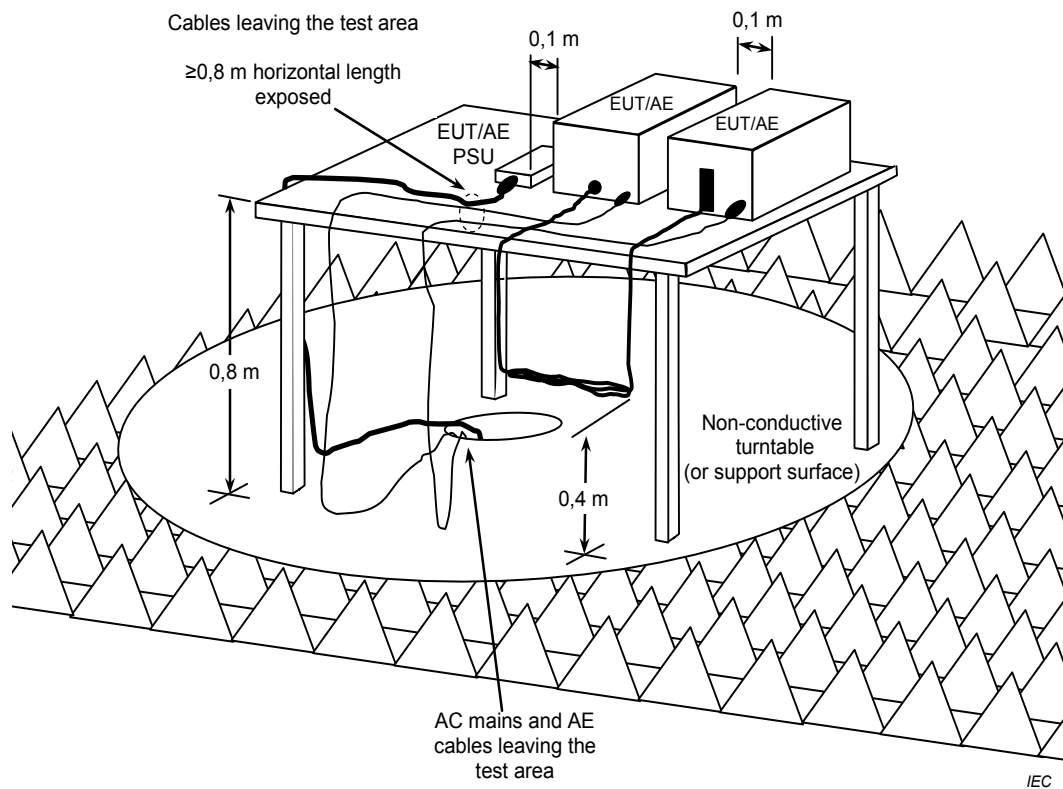

Figure D.11 – Example measurement arrangement for tabletop EUT (radiated emission measurement within a FAR)

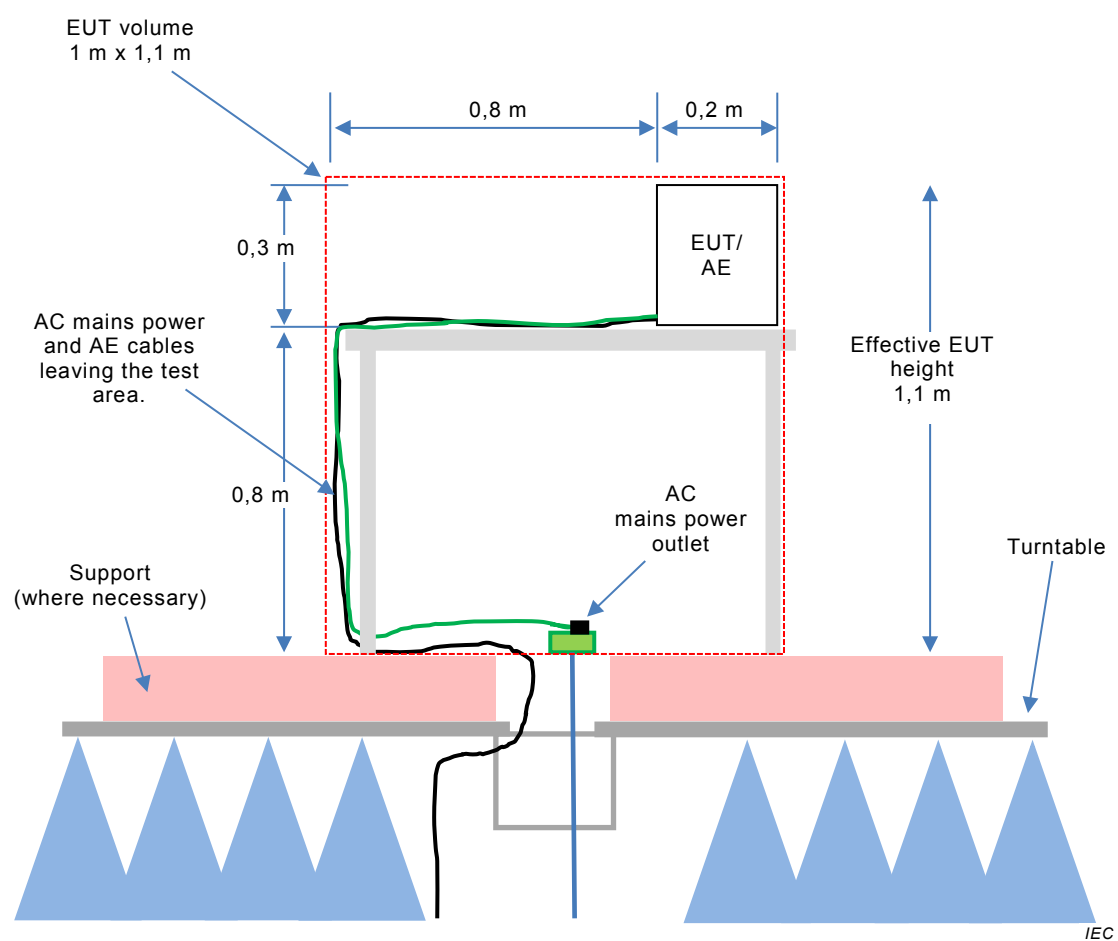

Figure D.12 – Example cable configuration and EUT height (radiated emission measurement within a FAR)

Annex E (informative)

Prescan measurements

The purposes of a prescan measurement are to determine the frequencies at which an EUT produces the highest level of emissions and to help select the configuration(s) to be used in the formal measurements.

Prescanning should be performed on various EUT configurations to find the configuration(s) that produce(s) the highest amplitudes with respect to the limit. This configuration should then be used during formal measurements.

The number of configurations to be considered is dependent upon the complexity of the EUT. Therefore, a quick and simple procedure should be established for comparative purposes so that the impact of varying the configuration can be found. Changes in configurations which may be considered include:

- mode of operation, as defined in 3.1.23;
- supply voltage discussed in A.1;
- arrangement discussed in Annex D;
- number and arrangement of modules within a system. See Figure 2;
- number of cables attached applying the criteria in D.1.1;
- position of cables, local AE and HID as required in Annex D.

The prescan method attempts to closely emulate the formal procedure so that effective comparisons can be achieved. For example, a limited height SAC would be an appropriate prescan facility followed by an OATS/SAC for formal measurements. An effective prescan will give confidence that the configuration which produces the highest amplitude emission with respect to the limit has been found.

Prescan measurements may be performed with spectrum analysers without pre-selection provided that precautions are used to ensure that the instrument is not overloaded.

A simple procedure to check for overload is to repeat a measurement with an attenuator (for example, 6 dB) added at a convenient point in the measurement path so that the signal present at any active or nonlinear stage of the measurement path (amplifiers, limiters, receivers, and so forth) is reduced by a known amount. If the measured signal level does not decrease by approximately the value of the attenuator used (within 0,5 dB), then the measurement system may be overloaded and steps should be taken to correct the problem. Further details are given in Annex B of CISPR 16-2-1:2008/ AMD 1:2010 /AMD2:2013.

Annex F (informative)

Test report contents summary

Guidance for compiling a test report can be found in ISO IEC 17025. References to ISO IEC 17025:2005 and requirements defined in relevant clauses of that standard are given in Table F.1. See Clause 9 for general reporting requirements. Additional information may also be added to the test report as necessary.

Table F.1 – Summary of information to include in a test report

Item	CISPR 32 Clause or subclause	ISO IEC 17025:2005 clause or subclause	Details to be included
Measurement arrangement	Annex D	5.10.1	Description of the final configuration.
Host and modules	6.2	5.10.1	Description of the host and modules.
Applicability	8	5.10.3.1 a) and e)	Decision and justification not to measure.
Special measures	7	5.10.1	Description of special measures needed to ensure compliance.
Highest internal frequency	8	5.10.1	Value of F_X . See Table 1.
General guidance	9	5.10 all (5.10.2 especially)	At least: 1. Class of limit (Class A or Class B) that is appropriate for the EUT. 2. Mode of operation of the EUT. 3. How the ports were exercised.
General content	9	5.10.1, 5.10.2	Photographs of the measurement configuration and arrangement for the formal measurements
Emissions data and calculations	9, Annex A, C.2.2.4	5.10.1	Tabular data should be presented covering the requirements of C.2.2.4.
Emission details	9	5.10.1	Pertinent information for each emission.
AAN category	9	5.10.1	Category of AAN used during wired network port measurement.
Calculated Measurement uncertainty	9	5.10.3.1.c), 5.10.4.1 b), 5.10.4.2	Calculated measurement uncertainty for each measurement performed.
Compliance statement	9, 10	5.10.2 1), 5.10.3.1 b)	Class of limit whose requirements the EUT satisfies.
Measurement distance used	Annex A, C.2.2.4	5.10.1	Measurement distance used and, where relevant, how the limit was calculated.
Exercising of ports	Annex A, Annex B	5.10.1	Description of the procedures used to exercise the ports. Justification of any non-standard procedures used. Specifically for Ethernet: the data rate used.
Ambients	C.2.2.3	5.10.3.1 a)	Procedure used to reduce the impact of ambients.
Position of cables	Annex D	5.10.1	The disposition of the excess cable shall be noted. Also record cable lengths if those defined cannot be achieved.
Table-top EUT arrangement	Annex D	5.10.1	Measurement arrangement alternative used for the conducted emission measurement.
Floor-standing arrangement due to a physical hazard	D.1.1	5.10.1	The test report shall document the decision and justification to test in a floor-standing arrangement rather than a table-top arrangement due to a physical hazard.

Annex G (informative)

Support information for the measurement procedures defined in C.4.1.1

G.1 Schematic diagrams of examples of asymmetric artificial networks

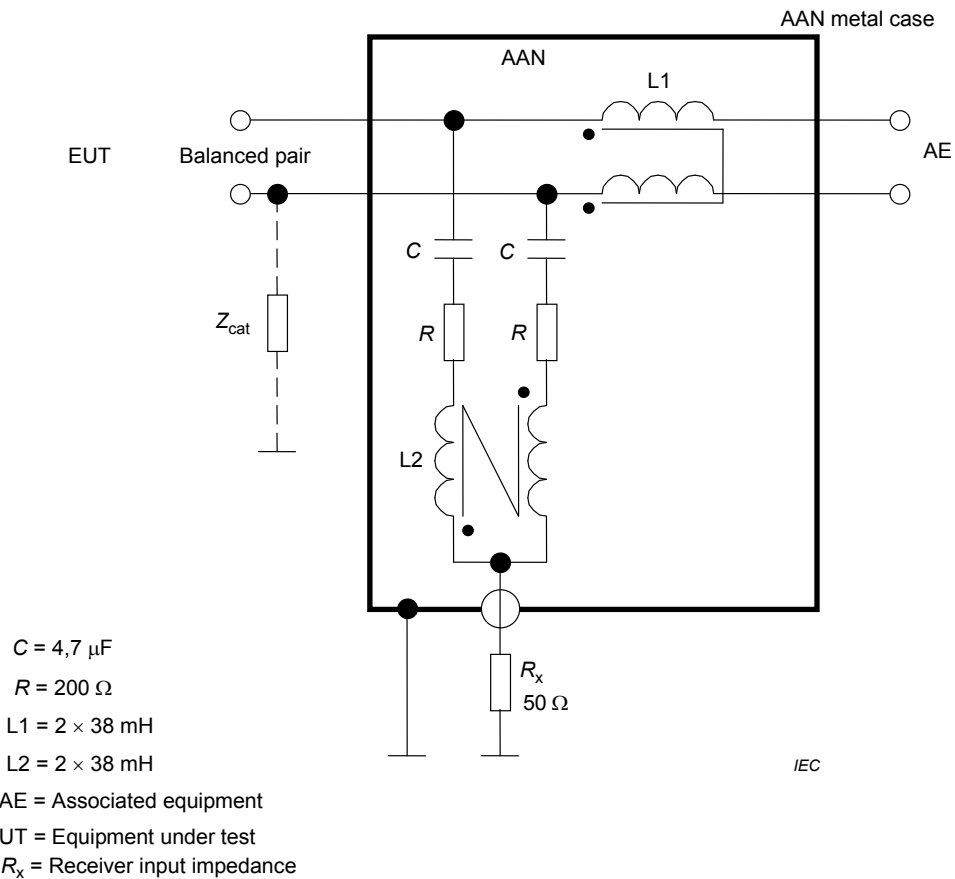

Nominal voltage division factor defined in C.4.1.2 e) = 9,5 dB.

Z_{cat} provides the unbalance required to adjust the LCL of the AAN to the values specified in Table C.2.

Figure G.1 – Example AAN for use with unscreened single balanced pairs

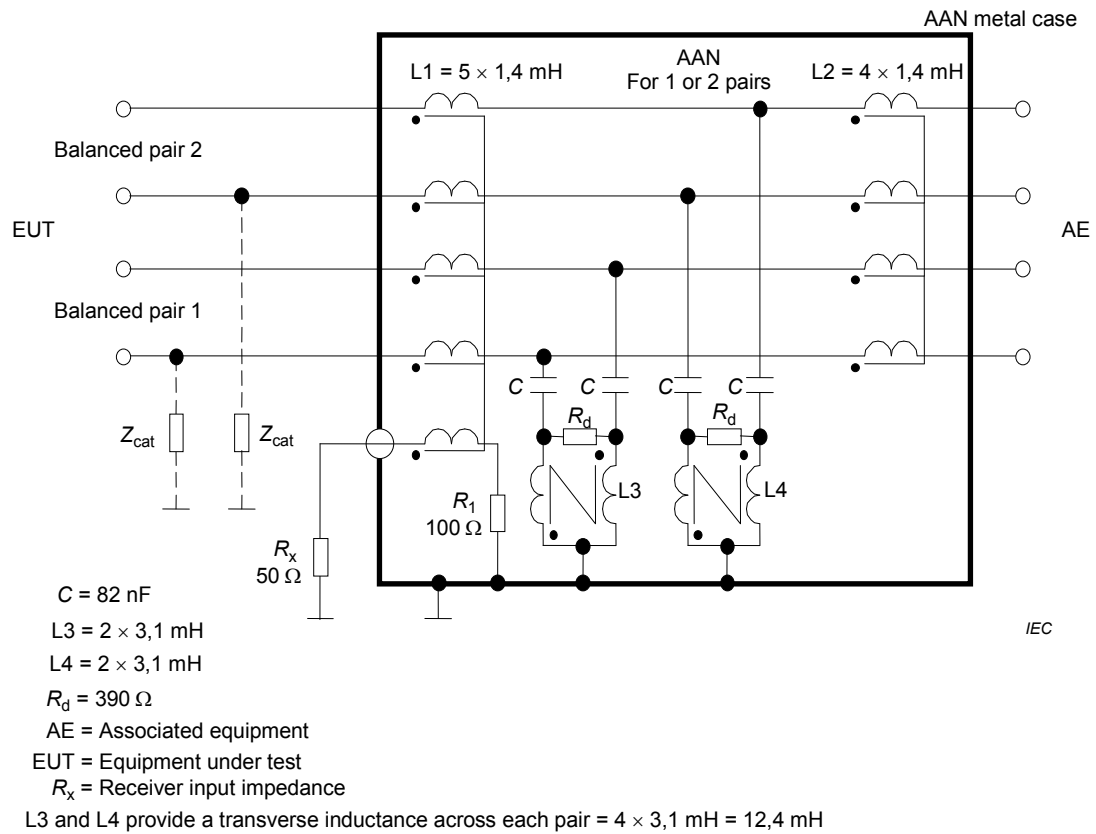

Nominal voltage division factor defined in C.4.1.2 e) = 9,5 dB.

Z_{cat} provides the unbalance required to adjust the LCL of the AAN to the values specified in Table C.2.

This AAN can be used to measure common mode emissions equally well on a single unshielded balanced pair or on two unshielded balanced pairs.

Figure G.2 – Example AAN with high LCL for use with either one or two unshielded balanced pairs

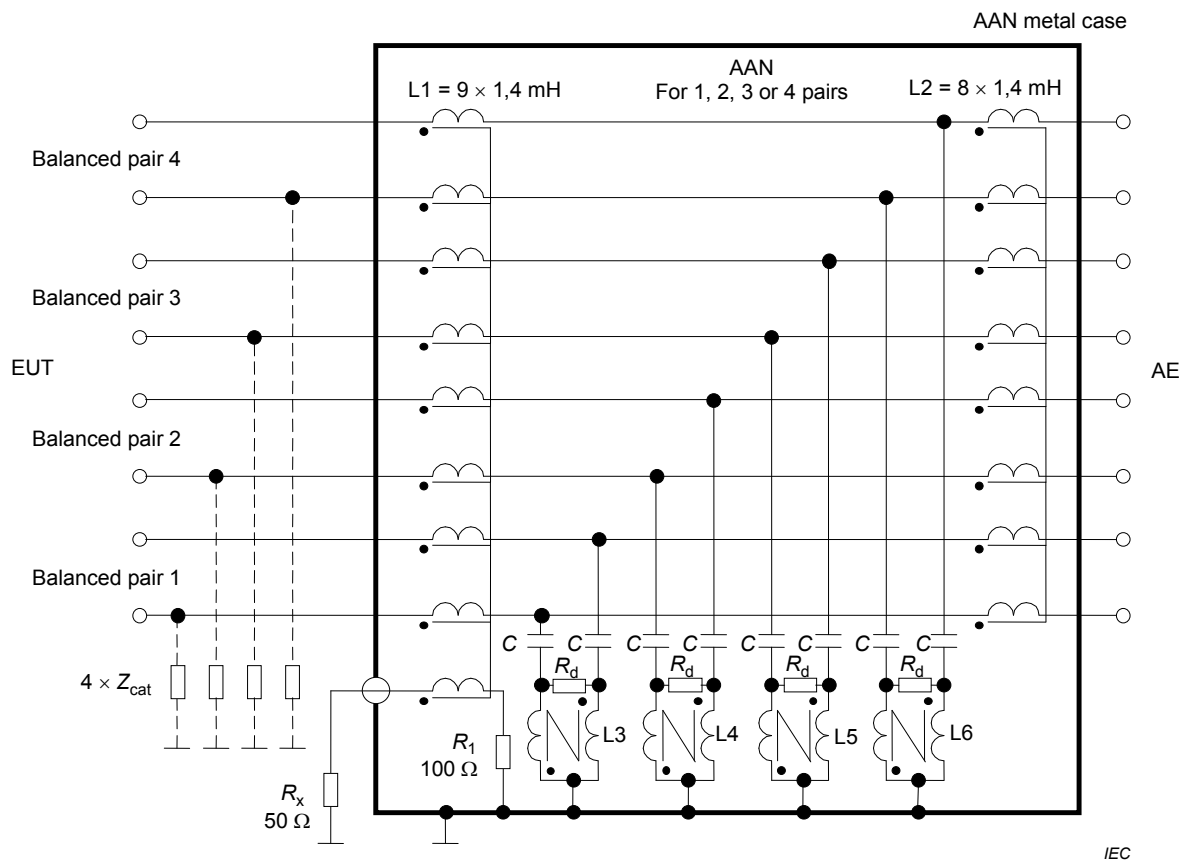

$C = 82 \text{ nF}$

$R_d = 390 \Omega$

AE = Associated equipment

EUT = Equipment under test

R_x = Receiver input impedance

$L3, L4, L5$ and $L6 = 2 \times 3,1 \text{ mH}$

$L3, L4, L5,$ and $L6$ provide a transverse inductance across each pair = $4 \times 3,1 \text{ mH} = 12,4 \text{ mH}$

Nominal voltage division factor defined in C.4.1.2 e) = 9,5 dB.

Z_{cat} provides the unbalance required to adjust the LCL of the AAN to the values specified in Table C.2.

This AAN can be used to measure common mode emissions equally well on a single unshielded balanced pair, or on two, three or four unshielded balanced pairs.

Figure G.3 – Example AAN with high LCL for use with one, two, three, or four unshielded balanced pairs

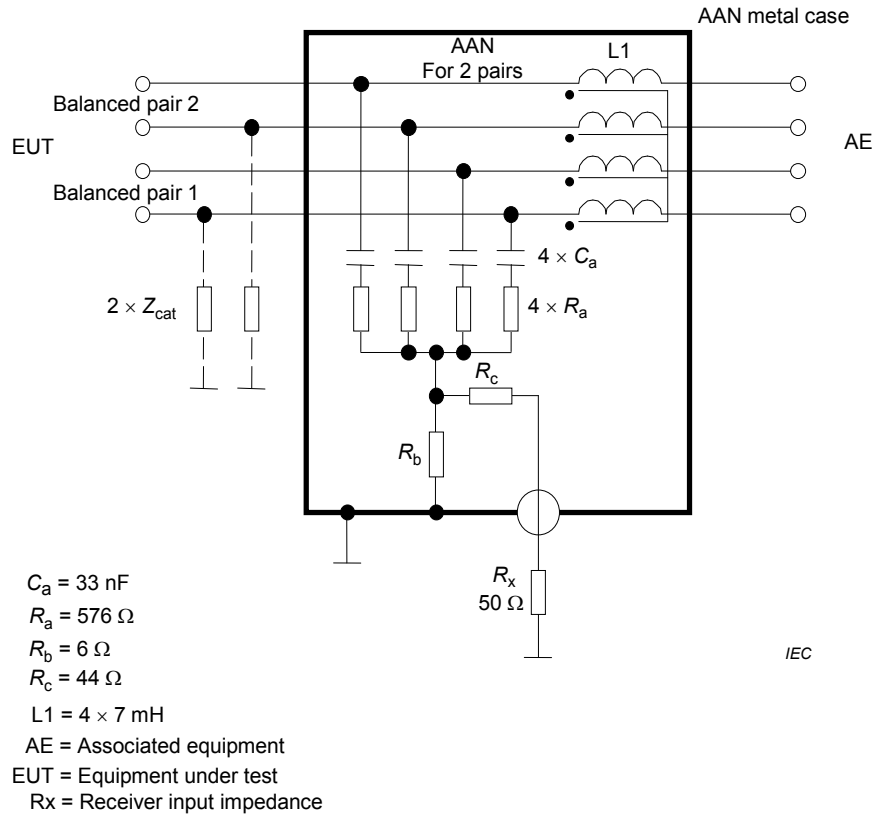

Nominal voltage division factor defined in C.4.1.2 e) = 34 dB.

Z_{cat} provides the unbalance required to adjust the LCL of the AAN to the values specified in Table C.2.

This AAN should not be used for cables which have at least one unused pair, see C.4.1.3

Figure G.4 – Example AAN, including a 50 Ω source matching network at the voltage measuring port, for use with two unscreened balanced pairs

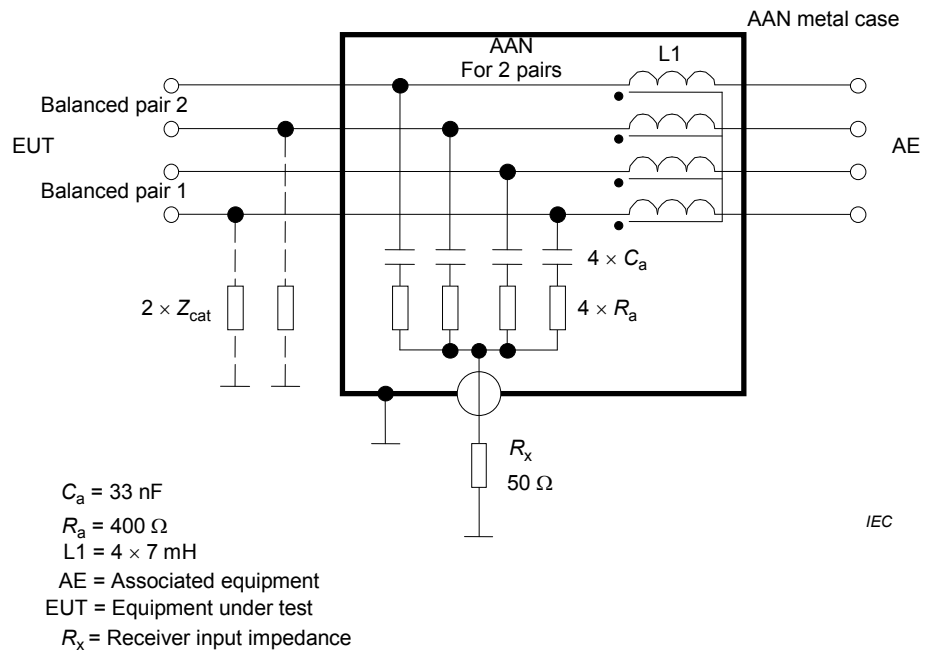

Nominal voltage division factor defined in C.4.1.2 e) = 9,5 dB.

Z_{cat} provides the unbalance required to adjust the LCL of the AAN to the values specified in Table C.2.

This AAN should not be used for cables which have at least one unused pair, see C.4.1.3.

Figure G.5 – Example AAN for use with two unscreened balanced pairs

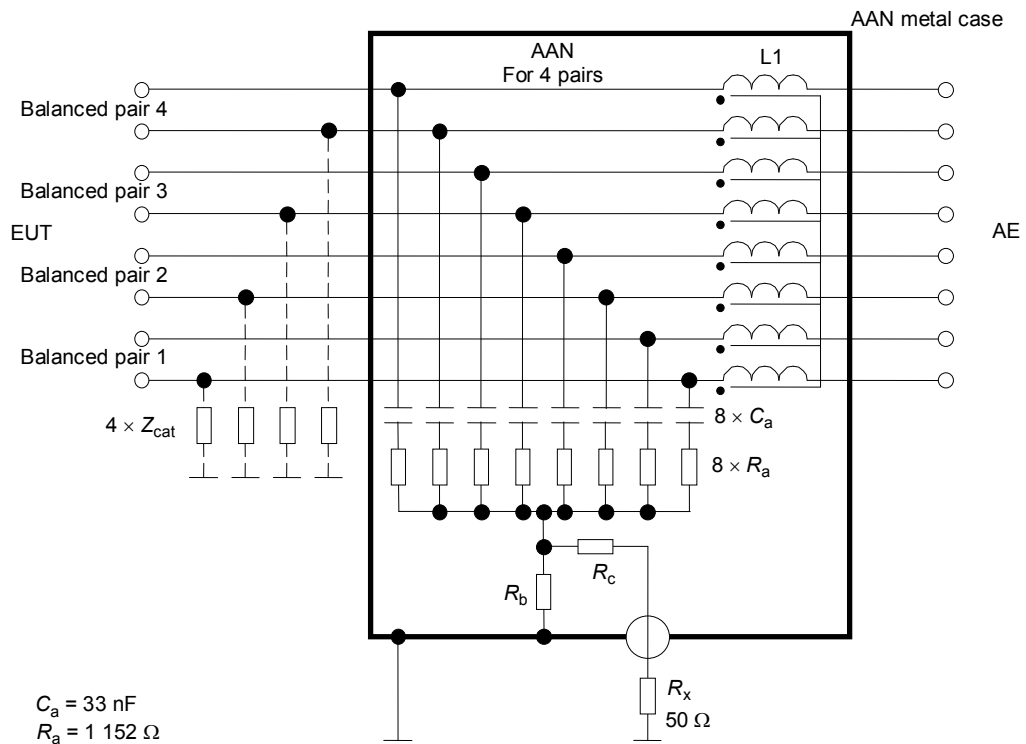

$$C_a = 33 \text{ nF}$$

$$R_a = 1\,152 \text{ } \Omega$$

$$R_b = 6 \text{ } \Omega$$

$$R_c = 44 \text{ } \Omega$$

$$L1 = 8 \times 7 \text{ mH}$$

AE = Associated equipment

EUT = Equipment under test

R_x = Receiver input impedance

IEC

Nominal voltage division factor defined in C.4.1.2 e) = 34 dB.

Z_{cat} provides the unbalance required to adjust the LCL of the AAN to the values specified in Table C.2.

This AAN should not be used for cables which have at least one unused pair, see C.4.1.3.

Figure G.6 – Example AAN, including a 50 Ω source matching network at the voltage measuring port, for use with four unscreened balanced pairs

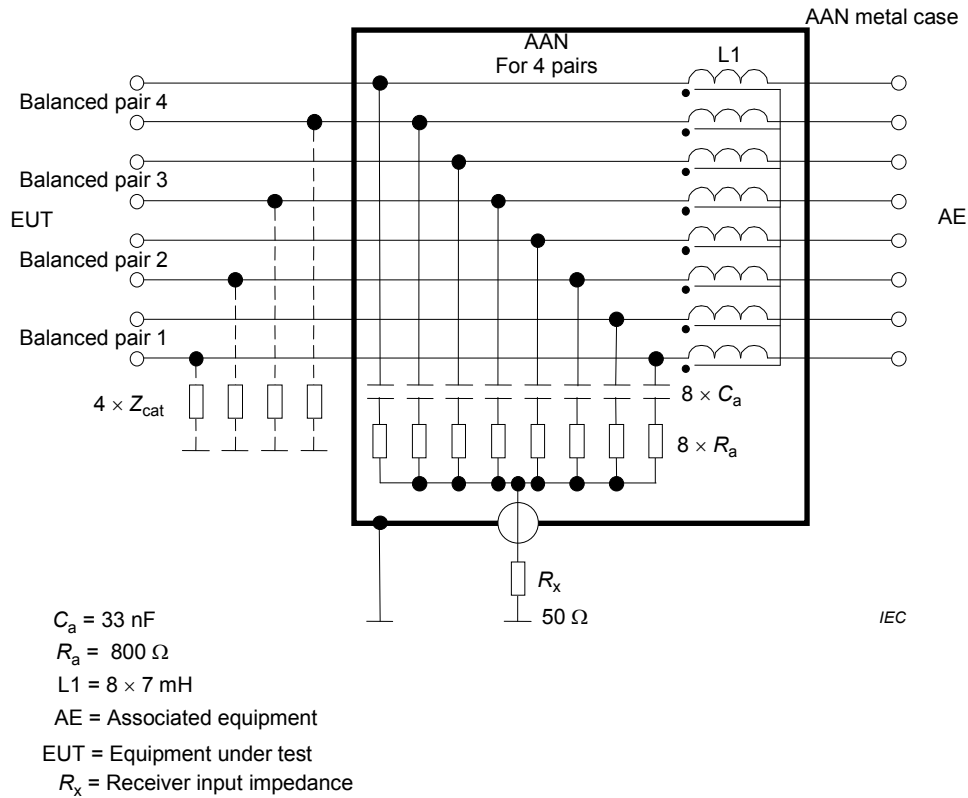

Nominal voltage division factor defined in C.4.1.2 e) = 9,5 dB.

Z_{cat} provides the unbalance required to adjust the LCL of the AAN to the values specified in Table C.2.

This AAN should not be used for cables which have at least one unused pair, see C.4.1.3.

Figure G.7 – Example AAN for use with four unscreened balanced pairs

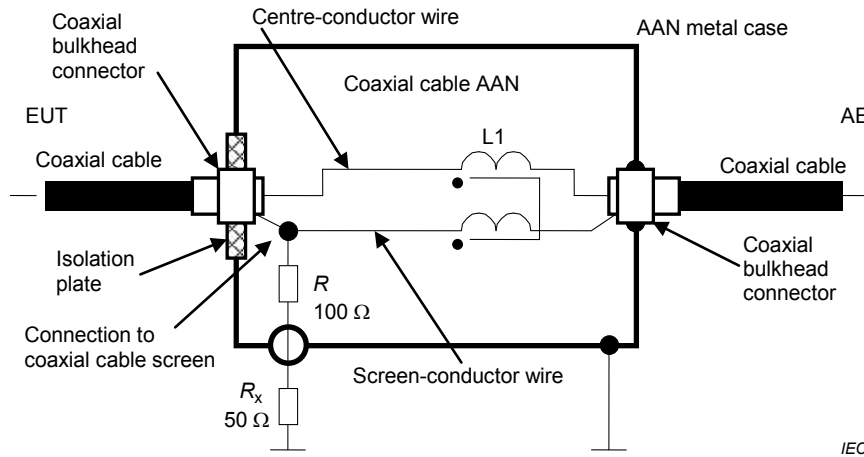

AE = Associated equipment
 EUT = Equipment under test
 R_x = Receiver input impedance
 Common mode choke $L_1 = 2 \times 7 \text{ mH}$

NOTE Nominal voltage division factor defined in C.4.1.2 e) = 9,5 dB.

Figure G.8 – Example AAN for use with coaxial cables, employing an internal common mode choke created by bifilar winding an insulated centre-conductor wire and an insulated screen-conductor wire on a common magnetic core (for example, a ferrite toroid)

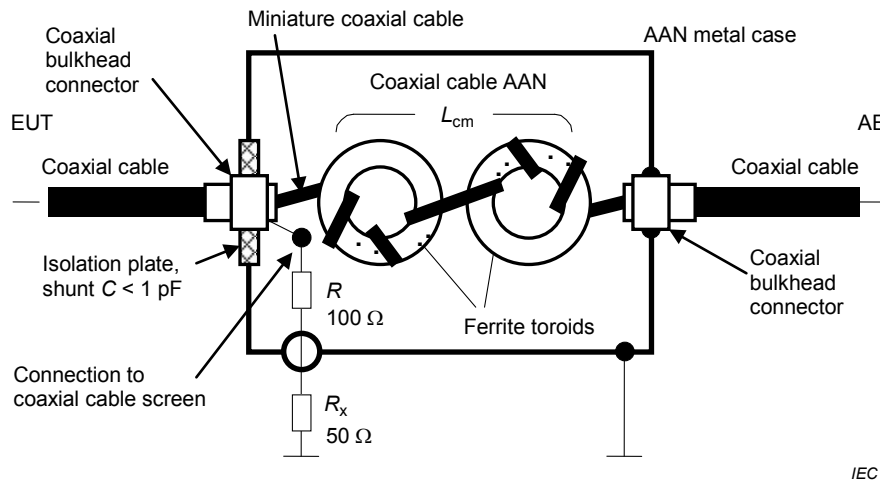

AE = Associated equipment
 EUT = Equipment under test
 R_x = receiver input impedance
 Common mode choke $L_{cm} > 9 \text{ mH}$, total parasitic shunt $C < 1 \text{ pF}$

Nominal voltage division factor defined in C.4.1.2 e) = 9,5 dB.

More toroids may be needed to fully meet the requirements for AANs.

Figure G.9 – Example AAN for use with coaxial cables, employing an internal common mode choke created by miniature coaxial cable (miniature semi-rigid solid copper screen or miniature double-braided screen coaxial cable) wound on ferrite toroids

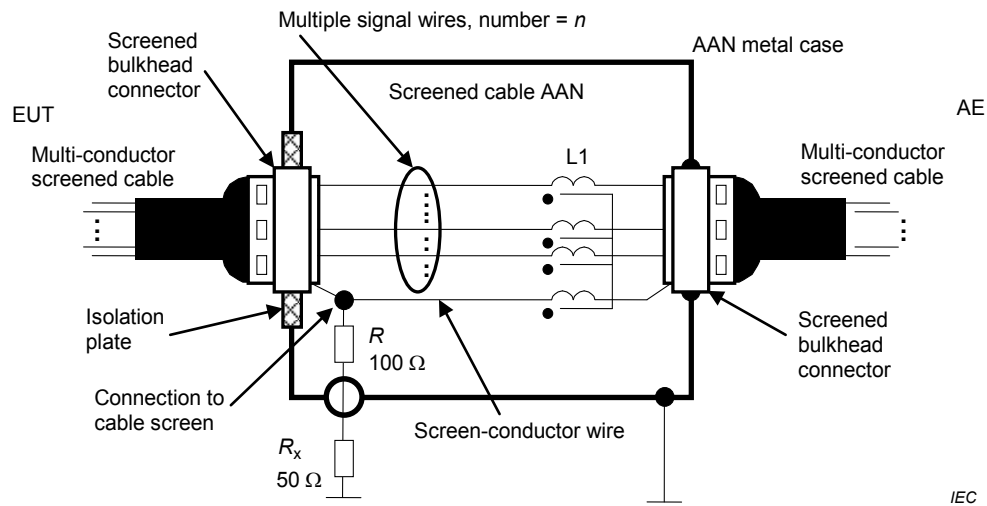

IEC

AE = Associated equipment
 EUT = Equipment under test
 R_x = Receiver input impedance
 Common mode choke $L1 = (n + 1) \times 7\ \text{mH}$, where n = number of signal wires

NOTE Nominal voltage division factor defined in C.4.1.2 e) = 9,5 dB.

Figure G.10 – Example AAN for use with multi-conductor screened cables, employing an internal common mode choke created by multifilar winding multiple insulated signal wires and an insulated screen-conductor wire on a common magnetic core (for example, a ferrite toroid)

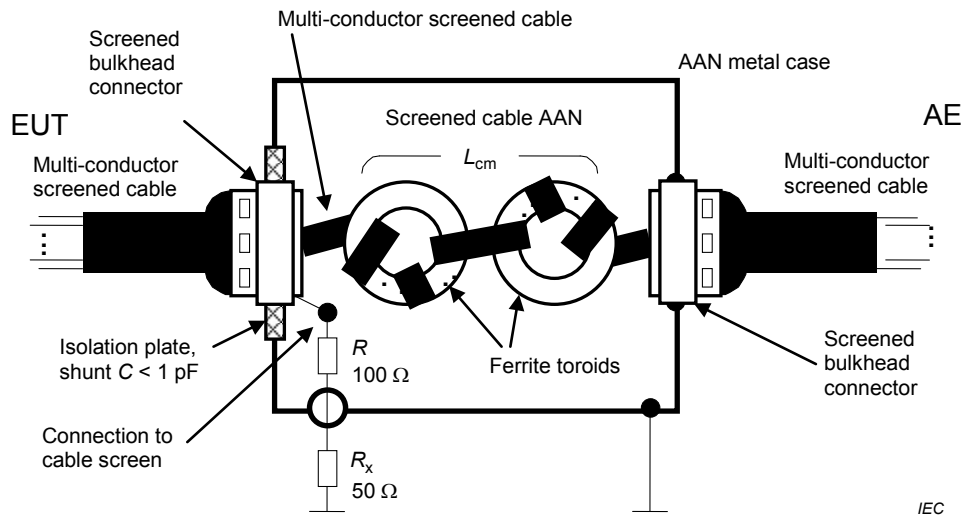

AE = Associated equipment
 EUT = Equipment under test
 R_x = Receiver input impedance
 Common mode choke $L_{cm} > 9$ mH, total parasitic shunt $C < 1$ pF

Nominal voltage division factor defined in C.4.1.2 e) = 9,5 dB.

More toroids may be needed to fully meet the requirements for AANs.

Figure G.11 – Example AAN for use with multi-conductor screened cables, employing an internal common mode choke created by winding a multi-conductor screened cable on ferrite toroids

G.2 Rationale for emission measurements and procedures for wired network ports

G.2.1 Limits

The emission voltage (or current) limit is defined for an asymmetric common mode load impedance of 150Ω (as seen by the EUT at the AE port during the measurement). This standardisation is necessary in order to obtain reproducible measurement results, independent of the undefined asymmetric common mode impedance at the AE and the EUT.

In general, the asymmetric common mode impedance seen by the EUT at the AE port is not defined unless an AAN is used. If the AE is located outside the shielded room, the asymmetric common mode impedance seen by the EUT at the AE port can be determined by the asymmetric common mode impedance of the feed through-filter between the measurement set-up and the outside world. A π -type filter has a low common mode impedance whilst a T-type filter has a high asymmetric common mode impedance.

AANs do not exist for all types of cables used by MME. It is therefore also necessary to define other (non-invasive) measurement procedures that do not use AANs.

Normally, there are several other cables (or ports) present at the EUT. At least the connection to the mains port is present in most cases. The asymmetric common mode impedance of these other connections (including a possible ground connection) and the presence or absence of these connections during the measurement can influence the measurement result significantly, particularly for small EUTs. Therefore the asymmetric common mode impedance of the non-measured connections has to be defined during the assessment of small EUTs. It is sufficient to have, in addition to the port being assessed, at least two additional ports connected to a 150Ω common mode impedance (normally by using an AAN with the RF

measurement port terminated with 50 Ω) in order to reduce this influence to a negligible amount.

Coupling devices for non-shielded balanced pairs should also simulate the typical LCL value of the lowest cabling category (worst LCL) specified for the wired network port being measured. The idea of this requirement is to take into account the transformation of the symmetrical signal into a asymmetric common mode signal, which might contribute to possible radiated disturbance when the EUT is used in the real application. Asymmetry in the AAN is deliberately introduced to yield the specified LCL value. This asymmetry may enhance or cancel the asymmetry of the EUT. In the interest of determining the worst case emissions and optimization of measurement repeatability, consideration should therefore be given to repeating the measurement with the LCL imbalance on each wire of a balanced pair when using the appropriate AAN as defined in C.4.1.2.

Since imbalance on each balanced pair will contribute to the total conducted common mode emission, all combinations of imbalance on all balanced pairs should be considered. For a single balanced pair, this has a relatively minor measurement impact – the two wires are reversed. However, for two balanced pairs, the number of LCL loading combinations (and therefore measurement configurations) is four. For four balanced pairs, the number of loading combinations grows to sixteen. Such numbers have a significant impact on measurement time and measurement documentation. Such measurements are not usually implemented, but if carried out the connection to AAN should be carefully documented.

The RF measurement port of an AAN not connected to the measuring receiver should be terminated with 50 Ω .

Table G.1 – Summary of advantages and disadvantages of the procedures described in C.4.1.6

Procedure	C.4.1.6.2	C.4.1.6.3	C.4.1.6.4
Advantages	For unshielded cables containing balanced pairs, the LCL values of the AAN are within the tolerance in Table C.2 of an AAN appropriate to the cable category connected to the EUT. Lowest measurement uncertainty	Non-invasive (except removing the insulation of the shielded cable) Always applicable to shielded cables Small measurement uncertainty for higher frequencies	Non-invasive Always applicable No underestimation (represents the worst case estimation)
Disadvantages	Only possible if appropriate AANs are available Invasive (needs appropriate cable connections) Needs an individual AAN for each cable type (results in a high number of different AANs) No isolation is generally provided by an AAN to symmetric signals from the AE	Increased measurement uncertainty for very low frequencies (<1 MHz) Alteration of the cable insulation is necessary Reduced isolation against emissions from the AE side (compared to the procedure in C.4.1.6.2) Only applicable to shielded cables	Overestimation is possible if common mode impedance at the AE is not close to 150 Ω Increased uncertainty for some extreme conditions of frequency and impedance No isolation against emissions from the AE side (compared to the procedure in C.4.1.6.3) Does not assess the interference potential that arises due to conversion of the symmetric signal due to the LCL of the cable network to which the EUT will be connected

G.2.2 Combination of current probe and CVP

The procedure described in C.4.1.6.4 has the advantage of being applicable in a non-invasive way to all types of cables. However, unless the asymmetric common mode impedance seen

by the EUT at the AE connection is $150\ \Omega$, the procedure in C.4.1.6.4 will show a result which is in general too high, but never too low (worst case estimation of the emission).

G.2.3 Basic ideas of the CVP

The method described in C.4.1.6.4 uses a CVP to measure the asymmetric common mode voltage. There are two approaches to the construction of a CVP. For either approach, if a $150\ \Omega$ common mode impedance is present, the capacitance of the CVP to the cable attached to the EUT port being assessed will appear as a load in parallel with the $150\ \Omega$ common mode impedance.

The common mode impedance tolerance is $\pm 20\ \Omega$ over the frequency range of 0,15 MHz to 30 MHz. If the CVP loading is to reduce the $150\ \Omega$ common mode impedance down to no less than $130\ \Omega$, the capacitive loading of the CVP to the cable attached to the EUT port being assessed should be $\leq 5\ \text{pF}$ at 30 MHz (the worst case frequency). At 30 MHz, the impedance of $5\ \text{pF}$ is approximately $1\ 061\ \Omega$, which, in parallel with $150\ \Omega$ results in a combined common mode impedance of approximately $131,4\ \Omega$.

A first possible CVP construction approach is for the probe to be a single capacitor that relies on physical distance from the cable attached to the EUT port being measured to achieve the $<5\ \text{pF}$ loading. This style of CVP is described in 5.2.2 of CISPR 16-1-2:2003/ AMD 1:2004/ AMD 2:2006.

A second possible construction uses two coupling devices in series. A first capacitive coupling device in close proximity to the cable attached to the EUT port being assessed (the device is actually in physical contact with the insulation of the cable attached to the EUT port being assessed). The second device is a standard oscilloscope-type voltage probe having an impedance $>10\ \text{M}\Omega$ with a probe capacitance $<5\ \text{pF}$. The theory is that the probe capacitance in series with the capacitance of the capacitive coupling device presents only the probe capacitance to the cable attached to the EUT port being assessed. In practice, it is possible, given the physical size of the capacitive coupling device, to have a large stray capacitance in parallel with the probe capacitance. If this occurs, the total capacitive loading will be greater than that of the probe itself, and the requirement to have $<5\ \text{pF}$ loading may be violated. If this technique is employed, the capacitive loading should be verified by measurement and not rely on theory. This capacitance measurement can be made with any capacitance meter that can operate over the 0,15 MHz to 30 MHz frequency range. The capacitance is measured between the cable attached to the EUT port being assessed (all wires in the cable are connected together at the connection point to the meter) and the RGP. The same type of cable used in the conducted emissions measurement should be used for this capacitance measurement.

NOTE This procedure has the lowest uncertainty if the length of cable between the EUT and AE is less than 1,25 m. Significantly longer cables are subject to standing waves that can adversely affect voltage and current measurements. For long cables where both the voltage and current limits cannot be met, changes to the measurement configuration can be implemented.

G.2.4 Combination of current and voltage limit

If the common mode impedance is not $150\ \Omega$, the measurement of the voltage or the current alone is not acceptable because of a very high measurement uncertainty due to the undefined and unknown common mode impedances. If however both voltage and current are measured with current and voltage limits applied simultaneously, the result is a worst case estimation of the emission as explained below. The basic circuit for which the limit is defined is shown in Figure G.12.

This circuit is the reference for which current and voltage limits are derived. Any other measurement has to be compared to this basic circuit. Z_1 is an unknown parameter of the EUT. Z_2 is $150\ \Omega$ in the reference measurement.

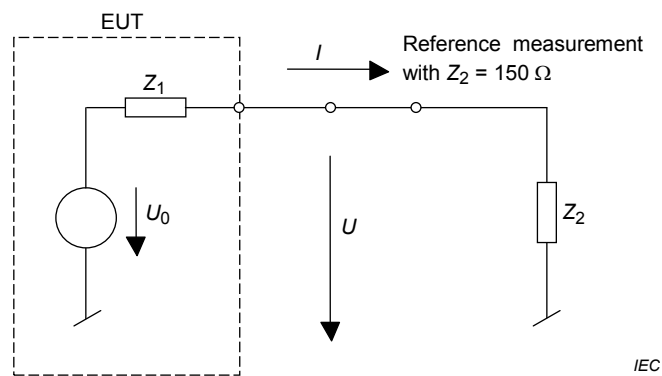

Figure G.12 – Basic circuit for considering the limits with defined common mode impedance of 150 Ω

If the measurement is performed without defining the common mode impedance seen by the EUT, the simplified circuit is as shown in Figure G.12, where the common mode impedance Z_2 seen by the EUT is defined by the AE and can have any value. Therefore Z_1 as well as Z_2 are unknown parameters of the measurement.

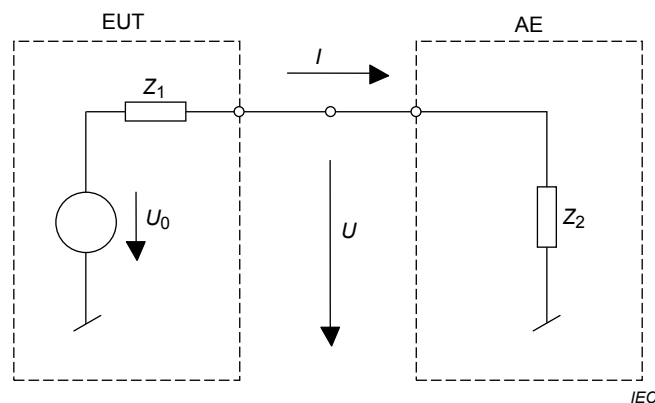

Figure G.13 – Basic circuit for the measurement with unknown common mode impedance

If the measurement is performed according to the circuit of Figure G.12 the limit of current and the limit of voltage are equivalent. The relation between current and voltage are always 150 Ω and either of the two can be used to determine the compliance with the limit. This is not the case if Z_2 is not 150 Ω. See Figure G.13.

It is important to be aware that the source voltage U_0 is not the only quantity determining the compliance with the limit. The disturbance voltage has to be measured at a standardized Z_2 of 150 Ω, while U in Figure G.13 depends on Z_1 , Z_2 , and U_0 together. The limit value can be reached with an EUT containing a high impedance Z_1 and a high source voltage U_0 , or with a lower U_0 combined with a lower impedance Z_1 .

In the more general case of Figure G.13 where Z_2 is not defined, it is not possible to measure the exact value of the interference voltage. Since Z_1 and U_0 are not known, it is not possible to derive the interference voltage, even if the value of Z_2 is known (or is measured or calculated from I and U). If for example an EUT, having excessive emissions, is measured only by determining the voltage in an arrangement with low Z_2 ($Z_2 < 150 \Omega$) at the AE side, then the EUT might seem to comply with the limits. By contrast, if the same EUT is measured only by measuring the current in a measurement set-up with high Z_2 , (for example by adding ferrites) the EUT might again seem to comply with the limits.

However, it can be shown that, if the current limit and the voltage limit are applied simultaneously, an EUT with emissions exceeding the limits is always discovered by exceeding either the current limit (if Z_2 is $<150 \Omega$) or the voltage limit (if Z_2 is $>150 \Omega$).

If the common mode impedance of the AE (Z_2) is far from 150Ω , it is possible that an EUT, which would comply with the limits if measured with $Z_2 = 150 \Omega$, may be rejected. However an EUT not complying with the limits will never be accepted. The measurement according to C.4.1.6.4 is therefore a worst case estimation of the emission. If an EUT exceeds the limit with this procedure, it is possible the EUT would comply with the limits if it could be measured with $Z_2 = 150 \Omega$. If emission measurements of the EUT by this procedure were compared to a power limit derived from the voltage and current limits, a more accurate measure of the interference potential into 150Ω is possible.

G.2.5 Ferrite requirements for use in C.4.1.1

Subclause C.4.1.6.3 defines a measurement set-up for measuring the common mode conducted emissions on the shield of a shielded cable. A 150Ω load is specified to be connected between the cable shield and the RGP as described in C.4.1.6.3. Ferrites are shown placed over the cable shield between the 150Ω load and the AE. The characteristics of the ferrites necessary to satisfy the requirements of C.4.1.6.3 are given below.

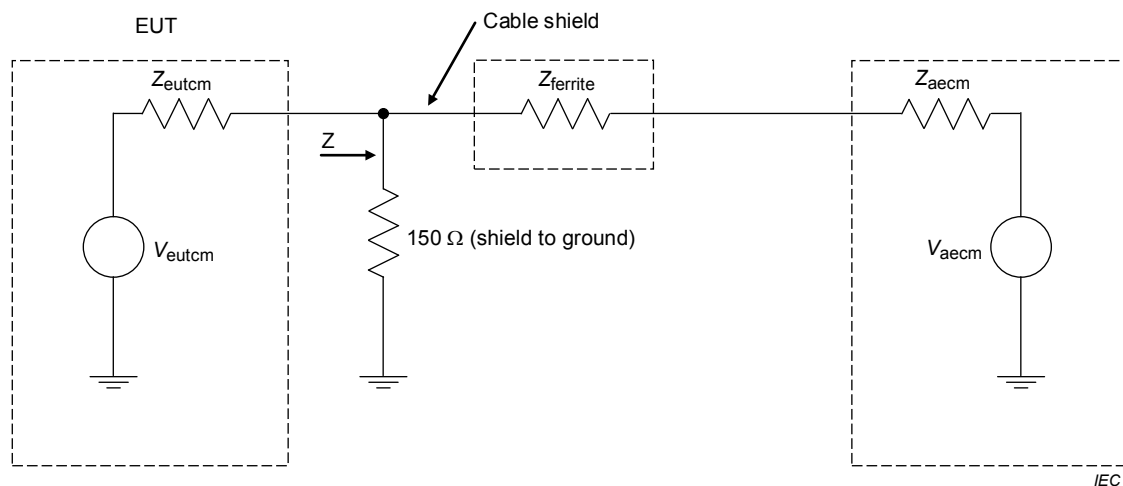

Key

V_{eutcm}	common mode voltage generated by the EUT
Z_{eutcm}	common mode source impedance of the EUT
V_{aecm}	common mode voltage generated by the AE
Z_{aecm}	common mode source impedance of the AE
$Z_{ferrite}$	impedance of the ferrites

NOTE The combined impedance (Z) is 150Ω , in parallel with the series combination of $Z_{ferrite}$ and Z_{aecm} .

Figure G.14 – Impedance layout of the components in the method described in C.4.1.6.3

Figure G.14 shows all of the basic impedances involved in the method described in C.4.1.6.3. The ferrites are specified in C.4.1.6.3 to provide a high impedance such that “...the common mode impedance towards the right of the 150Ω resistor shall be sufficiently large as to not affect the measurement.” This impedance is shown in Figure G.14 as $Z_{ferrite}$ in series with Z_{aecm} .

The above quotation from C.4.1.6.3 infers that the combined series impedance of $Z_{ferrite}$ and Z_{aecm} should not load down the 150Ω resistor. The general approach in this standard for

tolerance on 150 Ω common mode loads is $\pm 20 \Omega$ over the frequency range of 0,15 MHz to 30 MHz. Combining these two concepts, the combined series impedance of Z_{ferrite} and Z_{aecom} in parallel with the 150 Ω resistor (Z in Figure G.14) should be no lower than 130 Ω. This in turn implies that this relationship should hold regardless of the value of Z_{aecom} .

This clause provides guidance on the use of ferrites in cause C.4.1.1.

To establish the impedance characteristics of the ferrites, only two cases need to be considered: $Z_{\text{aecom}} = \text{open circuit}$ and $Z_{\text{aecom}} = \text{short circuit}$. If the ferrites can be selected to satisfy these requirements, any value of Z_{aecom} will be acceptable.

- Case 1: $Z_{\text{aecom}} = \text{open circuit}$

The combined series impedance of Z_{ferrite} and Z_{aecom} is also an open circuit. An open circuit in parallel with the 150 Ω load is 150 Ω. Z_{ferrite} can be of any value.

- Case 2: $Z_{\text{aecom}} = \text{short circuit}$

The combined series impedance of Z_{ferrite} and Z_{aecom} is equal to Z_{ferrite} . The value of Z_{ferrite} in parallel with the 150 Ω resistor will then need to be no lower than 130 Ω. In equation form:

$$[(150)(Z_{\text{ferrite}})]/(150 + Z_{\text{ferrite}}) \geq 130 \Omega$$

Solving for Z_{ferrite} yields a value of 975 Ω. This implies that the ferrites selected for this application should have a minimum impedance of 975 Ω over the frequency range of 0,15 MHz to 30 MHz. For a given set of ferrites, the minimum impedance ($j\omega L$) will occur at the minimum frequency of 0,15 MHz.

Combining the two cases cited above, it is seen that Case 2 at 0,15 MHz sets the minimum requirements for the impedance of ferrites so this value (or greater) would be acceptable.

To determine whether the selected ferrites will accomplish the intended function, the measurement set-up shown in Figure G.15 is suggested. A traditional impedance meter or analyser can be used to measure the impedance between point Z and the reference ground. Another approach is to measure the individual voltage and current at point Z (I and V in Figure G.15) and calculate the impedance. As a minimum, the impedance measurement should be made at 0,15 MHz. It would be advisable, however, to measure the impedance across the entire 0,15 MHz to 30 MHz range to ensure that no stray capacitance associated with the ferrites and the shielded cable degrades the ferrite impedance. This is of concern since laboratory data have shown that it is unlikely that desired impedance can be achieved with a single pass of the shielded cable through the ferrites. Multiple passes through the ferrites are necessary. This increases chances of stray capacitance adversely affecting the impedance of the ferrites. The capability to achieve the desired impedance versus frequency has been demonstrated in the laboratory.

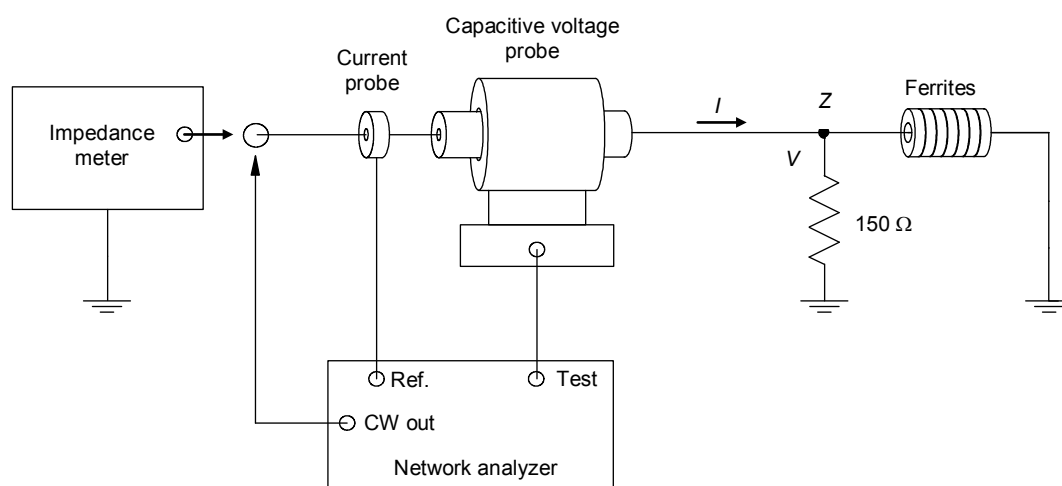

IEC

Figure G.15 – Basic measurement setup to measure combined impedance of the 150 Ω and ferrites

Annex H (normative)

Supporting information for the measurement of outdoor unit of home satellite receiving systems

H.1 Rationale

The emission limits given in Table A.7 are related to two possible interference cases.

- The limits given in table clauses A7.1 and A7.2 protect radio services from emissions in the frequency range from 30 MHz to 18 GHz due to outdoor units of home satellite receiving systems. These limits have the same purpose as the emission limits for other MME given in Annex A.
- The limits given in table clause A7.3 or A7.4 prevent interference to the uplink channel of a satellite transponder due to the totality of the LO frequencies emissions from the many outdoor units directed towards that satellite.

The LO emissions are amplified by the gain of the outdoor parabolic antenna. Therefore, in the direction of the satellite (to which the parabolic antenna is aligned), a relatively low emission limit of 37 dB(μ V/m) is specified for the LNB (see Table H.1).

The emission power limit in table clause A7.4 is calculated for an outdoor unit without a feed horn. Hence, if the feed horn cannot be separated from the outdoor unit, this measurement result shall be compensated by subtracting the value of the gain of the feed horn.

Table H.1 – Derivation of the limit within $\pm 7^\circ$ of the main beam axis

Factors used to calculate the limit	Calculated value
Based element is thermal noise (room temperature), -173 dBm/Hz	-113 dBm/MHz
Requested noise margin at the uplink receiver of the satellite	-10 dB
Allowed disturbance power at satellite receiver input	-123 dBm
Satellite receiving antenna gain	34 dBi
Allowed total disturbance power at satellite position.	-157 dBm
The number of LNBS directed at the satellite (50 000 000 is assumed, and $10 \times \text{LOG}(50\ 000\ 000) = 77$)	77 dB
Allowed disturbance power at satellite point emitted from one receiver.	-234 dBm
Propagation loss for 40 000 km distance	-207 dB
Allowed total disturbance power at LNB position	-27 dBm
Typical gain overall antenna of the home satellite receivers	33 dBi
Allowed disturbance power	-60 dBm
Allowed disturbance power (unit change from dBm to dBpW)	30 dBpW
Calculated radiated field strength limit from outdoor unit of home satellite receivers (half wave dipole, 3 m distance)	37 dB μ V/m

H.2 General

This annex supplements the general guidance and requirements of this standard.

Where possible, the outdoor unit (LNB) shall be measured without the parabolic reflector. The feed horn shall be attached to the LNB, except in the case of direct power measurement of the LO. In the majority of cases the LNB and feed horn cannot be separated. If the EUT is provided without a feed horn, then a typical feed horn shall be used for the measurement.

The limit for the measurement within $\pm 7^\circ$ of the main beam axis is for the LO terminal power. The limit shall be relaxed by the gain of the feed horn. The gain is specified at the centre frequency of the receiver band. If the gain of the feed horn is not specified, a standard value of 10 dBi shall be applied.

In the rare case of a non-detachable parabolic reflector, the reflector's gain shall be also added to the limit (or subtracted from the measurement result) for the measurement of the LO emission within $\pm 7^\circ$ of the main beam axis (limit in table clause A7.3).

H.3 Operation conditions

For the measurement of the LO leakage, the EUT shall be connected to the power supply (via a suitable bias tee) and control signals for switching the LO frequencies, if applicable.

For the measurement of spurious radiated emissions, the EUT needs an input signal which can be an un-modulated carrier. Therefore a suitable small transmit antenna shall be placed within the main beam axis of the EUT. The influence of the transmit antenna on the measurement result shall be reduced to a minimum. An example arrangement of the transmit antenna is shown in Figure H.2.

The input signal shall be adjusted to get the maximum rated output level from the EUT. For the measurement in the frequency range from 30 MHz to 1 GHz the input signal shall be adjusted so that the output frequency is within this frequency range. For the measurement in the frequency range above 1 GHz, the frequency of the input signal shall be adjusted in such a way that the EUT is measured, as a minimum, at the lowest, middle and highest rated output frequency within the measured frequency range. A typical scenario is as follows:

For an LNB with the following characteristics:

- maximum output level: –10 dBm,
- LO frequencies: 9,75 GHz and 10,6 GHz,
- output frequency ranges
 - 950 MHz to 1 950 MHz (for 9,75 GHz LO)
 - 1 100 MHz to 2 150 MHz (for 10,6 GHz LO)

the following output frequencies shall be measured with the EUT set to output level of – 10 dBm.

- LO frequency 9,75 GHz: 950 MHz, 1 450 MHz and 1 950 MHz
- LO frequency 10,6 GHz: 1 100 MHz, 1 625 MHz and 2 150 MHz

H.4 Specific requirements for LO measurement

In the case of a detachable feed horn, the radiated emission of the LO leakage within $\pm 7^\circ$ of the main beam axis can be measured directly by a power measurement at the feed horn interface. If a suitable interface (typically types R120, C120) is available, a power meter or spectrum analyzer can be connected to the LNB via a suitable adapter. Due allowance shall be made for the feed losses between the available interface and the antenna flange.

H.5 EUT arrangements

For the arrangement of the EUT the requirements of Annex D shall be satisfied. The EUT shall be measured as table-top equipment. AE such as the DC source, generator for control signals and measurement device for the output signal shall be placed outside of the measurement area. The power supply shall be connected via a suitable bias tee.

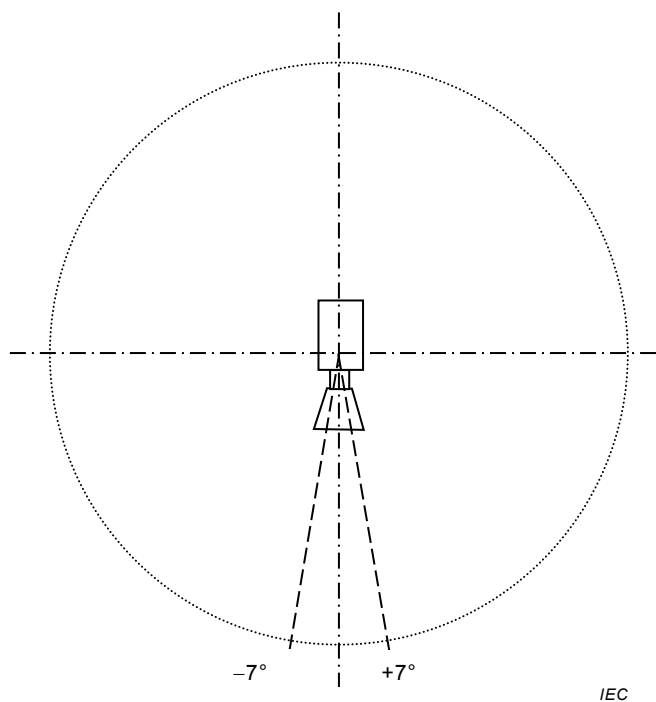

For EUT with a non-detachable parabolic reflector the main beam axis shall be changed to the opposite direction.

Figure H.1 – Description of $\pm 7^\circ$ of the main beam axis of the EUT

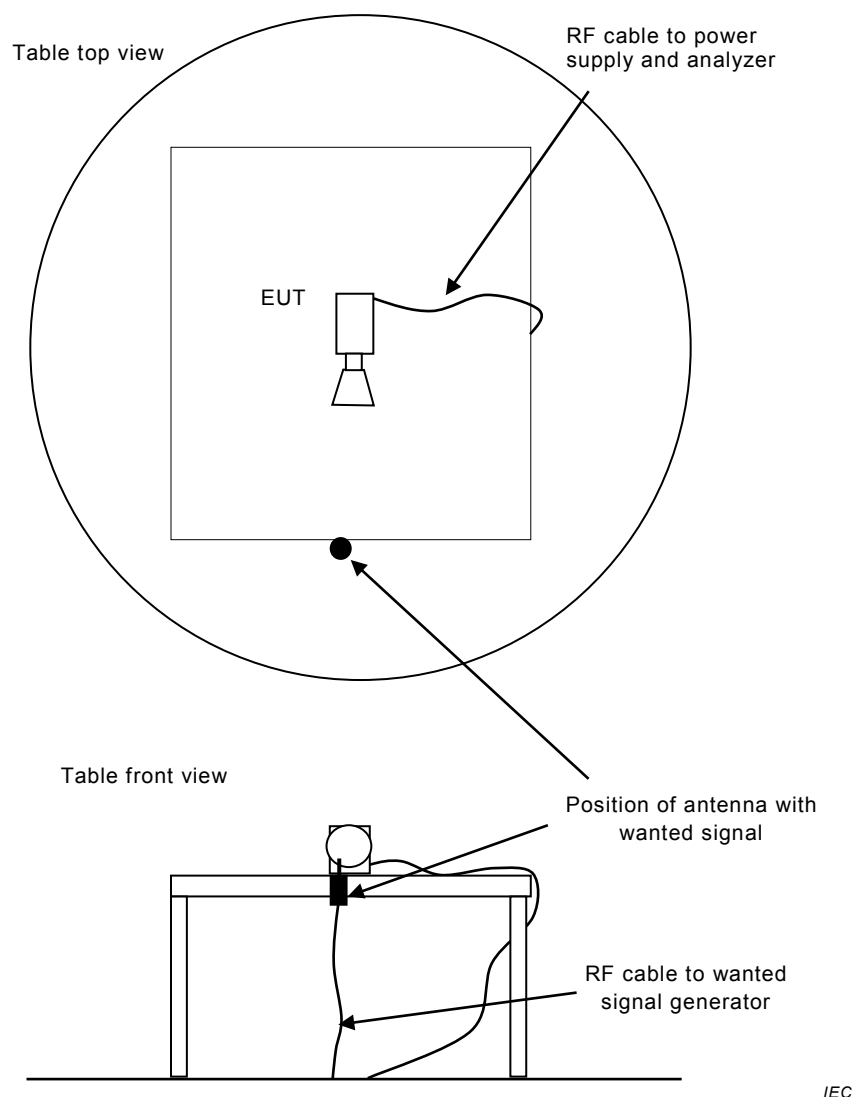

IEC

Figure H.2 – Example measurement arrangements of transmit antenna for the wanted signal

Annex I (informative)

Other test methods and associated limits for radiated emissions

I.1 General

The following test methods and associated limits are provided for information purposes. Meeting these limits using the alternative test methods does not constitute compliance with this publication. The alternative test methods and limits are described in Table I.1 to Table I.7.

NOTE Limits for reverberation chambers are still under evaluation and therefore the proposed limits can be changed in a future amendment to this publication.

Throughout this informative annex,

- where the amplitude of a limit varies over a given frequency range, it changes linearly with respect to the logarithm of the frequency;
- where there is a step in the relevant limit, the lower value should be applied at the transition frequency;
- if more than one detector is specified, the EUT should be assessed using all relevant detectors against the appropriate limit: this procedure can be optimised by use of the decision trees defined in Figure C.3 to Figure C.5.

I.2 Procedures for radiated emission measurements using a GTEM or RVC

The following limits and requirements are for information purposes only. They may provide equivalent protection to radio reception as those defined in Annex A and are included to give the user of these types of facilities an indication of the validity of the results.

NOTE There are no proposed limits for measurements using the RVC for frequencies below 1 GHz.

Table I.1 – Radiated emissions, basic standards and the limitation of the use of GTEM and RVC methods

Measurement Facility	Basic standard	Facility validated to maximum frequency of measurement and in accordance with	Measurement		Limitations
			Procedure	Arrangement	
GTEM	IEC 61000-4-20	IEC 61000-4-20	IEC 61000-4-20	Clause I.4	Measuring in a GTEM is limited to an EUT meeting the definition of 'small equipment' in IEC61000-4-20. In addition, EUTs containing cable ports cannot be measured using a GTEM.
RVC	IEC 61000-4-21	IEC 61000-4-21	IEC 61000-4-21	Clause I.5	EUT size is limited to the volume established during the validation process.
IEC 61000-4-20 and IEC 61000-4-21 are listed in the reference documents at the end of this annex.					

The following points refer to Table I.1.

- For RVC measurements, it will be necessary to convert the total radiated power to equivalent free space electric field values. This should be done using the method specified in IEC 61000-4-21:2011, Annex E [I6.7]⁶. The equivalent measurement distance to the EUT, R , is set to 3 m. The directivity, D , is set to 1,7 as recommended for dipole radiation. The radiated power is to be found using the maximum received power method in IEC 61000-4-21:2011, Equation (E.2). Using logarithmic units, in IEC 61000-4-21:2011, Equation (E.6) with the parameters above simplifies to:

$$E_{\text{rad}} = P_{\text{rad}} + 97,53 \text{ dB}$$

E_{rad} is the free-space electric field expected at a 3 m distance, in units of dB(μ V/m). P_{rad} is the radiated power in dBm units.

- The limits presented for the GTEM are based on the 10 m measurement distance on an OATS and 3 m on a FSOATS. Details for correlating OATS and GTEM-limits are given in Clause A.3 of IEC 61000-4-20:2010 [I6.5]. The small-EUT correction factor given in A.4.3 of IEC 61000-4-20 [I6.5] shall be used.

Table I.2 – Proposed limits for radiated emissions at frequencies up to 1 GHz for Class A equipment, for GTEM

Table clause	Frequency range MHz	Measurement			Class A limits dB(μ V/m)
		Facility	Distance m	Detector type / bandwidth	
I2.1	30 to 230	GTEM	n/a	Quasi peak / 120 kHz	40
	230 to 1 000	GTEM			47

Table I.3 – Proposed limits for radiated emission for frequencies above 1 GHz for Class A equipment, for GTEM

Table clause	Frequency range MHz	Measurement			Class A limits dB(μ V/m)
		Facility	Distance m	Detector type / bandwidth	
I3.1	1 000 to 3 000	GTEM	n/a	Average / 1 MHz	56
	3 000 to 6 000				60
	1 000 to 3 000	GTEM		Peak / 1 MHz	76
	3 000 to 6 000				80

Table I.4 – Proposed limits for radiated emission for frequencies above 1 GHz for Class A equipment, for RVC

Table clause	Frequency range MHz	Measurement			Class A limits dB(μ V/m)
		Facility	Distance m	Detector type / bandwidth	
I4.1	1 000 to 3 000	RVC	n/a	Average / 1 MHz	56
	3 000 to 6 000				60
	1 000 to 3 000	RVC		Peak / 1 MHz	76
	3 000 to 6 000				80

⁶ Numbers in square brackets refer to the reference documents at the end of this annex.

**Table I.5 – Proposed limits for radiated emissions
at frequencies up to 1 GHz for Class B equipment, for GTEM**

Table clause	Frequency range MHz	Measurement			Class B limits dB(μ V/m)
		Facility	Distance m	Detector type / bandwidth	
I5.1	30 to 230	GTEM	n/a	Quasi Peak / 120 kHz	30
	230 to 1 000	GTEM			37

**Table I.6 – Proposed limits for radiated emission
for frequencies above 1 GHz for Class B equipment, for GTEM**

Table clause	Frequency range MHz	Measurement			Class B limits dB(μ V/m)
		Facility	Distance m	Detector type / bandwidth	
I6.1	1 000 to 3 000	GTEM	n/a	Average / 1 MHz	50
	3 000 to 6 000				54
	1 000 to 3 000	GTEM		Peak / 1 MHz	70
	3 000 to 6 000				74

**Table I.7 – Proposed limits for radiated emission
for frequencies above 1 GHz for Class B equipment, for RVC**

Table clause	Frequency range MHz	Measurement			Class B limits dB(μ V/m)
		Facility	Distance m	Detector type/ bandwidth	
I7.1	1 000 to 3 000	RVC	n/a	Average / 1 MHz	50
	3 000 to 6 000				54
	1 000 to 3 000	RVC		Peak / 1 MHz	70
	3 000 to 6 000				74

I.3 Additional measurement procedure information

I.3.1 General

The following subclauses provide additional information over and above that given in 6.3.

Prescan measurements are performed to identify the one configuration to be measured during formal measurements, this configuration is then used to measure the maximum emission level.

I.3.2 Specific considerations for radiated emission measurements using a GTEM

The general considerations for measurements in a GTEM are contained in IEC 61000-4-20 [I6.5]. In a GTEM, the EUT should be rotated about three orthogonal axes.

Figure I.1 through Figure I.3 illustrate the EUT and the measurement setup in a GTEM.

I.3.3 Specific considerations for radiated emission measurements using an RVC

The general considerations for measurements in a reverberation chamber are contained in IEC 61000-4-21 [I6.7]. When testing in a reverberation chamber, the stirrers/tuners should be set to at least the minimum number of positions required under IEC 61000-4-21. In addition, alternative variations may include varying the speed of the stirrer.

I.4 Use of a GTEM for radiated emission measurements

I.4.1 General

The radiated emissions from an EUT can be measured using a TEM cell. A GTEM cell offers a much wider bandwidth than a conventional TEM cell, typically from nearly DC to several GHz. The theory and application of the GTEM cell for emission measurements is given in Annex A of IEC 61000-4-20:2010 [I6.5].

The purpose of this clause is to illustrate the construction of the GTEM with its component parts and how an EUT may be mounted to provide a frequency scan of the EUT's emission spectrum when mounted in 3 orthogonal positions.

I.4.2 EUT layout

Details on the measurement setup are given in A.5 of IEC 61000-4-20:2010 [I6.5].

The setup table should be made of non-conductive low-permittivity (ϵ_r) material (for example extruded polystyrene foam). Avoid using materials that are known to be conductive at certain frequencies, especially laminated wood or materials that will change RF behaviour due to environmental conditions (changes of humidity will generally affect wood). Apply for example extruded polystyrene foam boards.

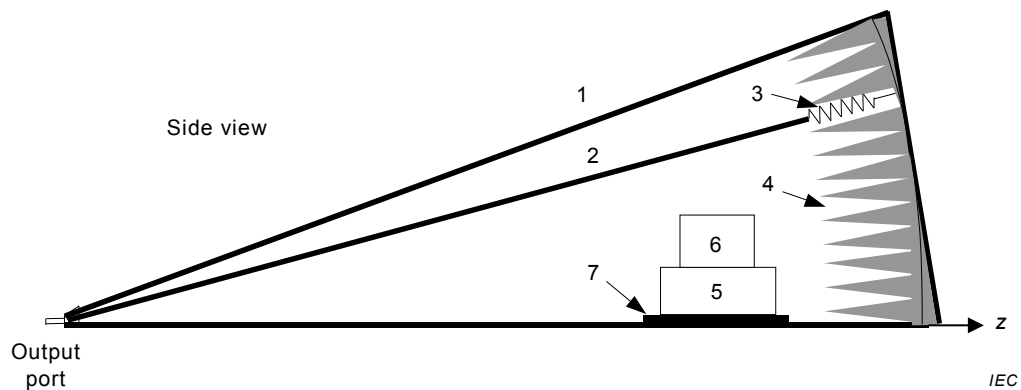

Description of the various parts of the GTEM

1. Chassis outer conductor
2. Septum inner conductor
3. Resistive load
4. RF absorber
5. Rotatable table
6. EUT
7. Optional ferrite tiles under EUT

Figure I.1 – Typical GTEM side sectional view showing some basic parts

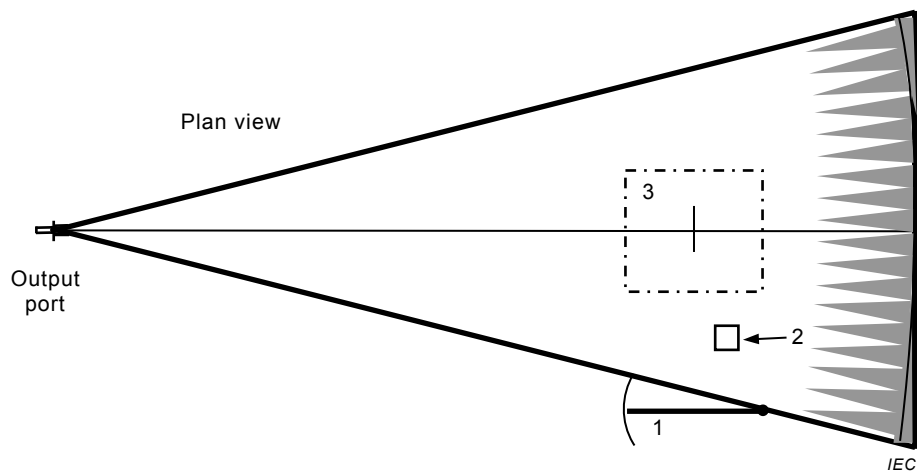

Description of the various elements within the diagram

1. Entry door
2. Floor penetration plate
3. Optional ferrite tiles under EUT

Figure I.2 – Typical GTEM plan sectional view showing floor layout

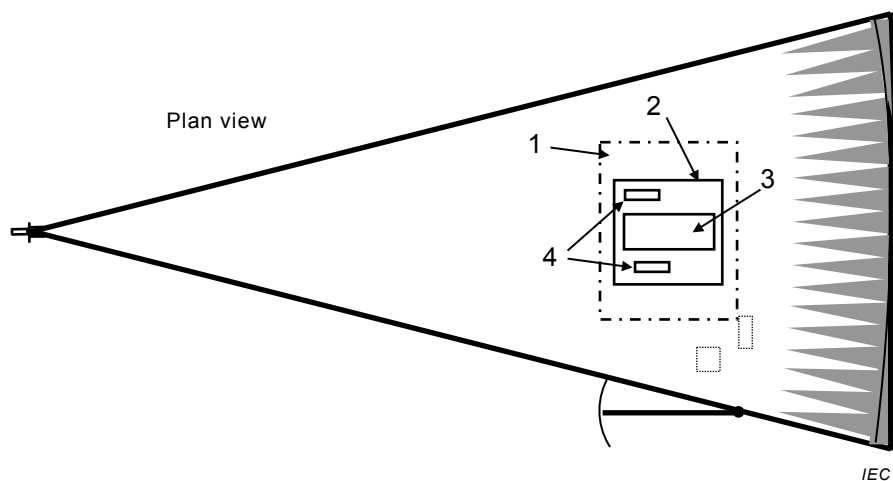

Description of the various elements within the diagram

1. Rotatable Table
2. Board with low loss strap or tape fixings
3. EUT fixed to board with low loss strap or tape.
4. AE

Figure I.3 – Typical EUT mounting for combination of modules being measured

I.4.3 GTEM, measurements above 1 GHz

In common with antenna measurement above 1 GHz a GTEM requires a different measurement technique than below 1 GHz. At these frequencies the emissions can have very narrow beam widths and so the EUT needs to be rotated in order to ensure the maximum amplitude is found. Rotating of the EUT in 5 degree steps is recommended. In this case the maximum value of emission can be recorded for each position over the full swept frequency range. See [I6.3] for further information.

I.4.4 Uncertainties

Information on measurement uncertainty can be found at page 30 of “*The Use of GTEM Cells for EMC Measurements*” [I6.4].

Errors caused by cross-polarization may be improved in the range of 125 MHz to 220 MHz by fitting ferrite tiles (100 mm × 100 mm × 6,5 mm) under the EUT table. This is only a problem with the larger cells. Typically the 1,75 m cell would use 64 tiles [I6.1].

Uncertainties can also be reduced by ensuring no part of the EUT is positioned below 15 % of the transmission line (septum) height [I6.2].

I.5 Specific EUT arrangement requirements for radiated emission measurements above 1 GHz using an RVC

The RVC is a fully reflective chamber that can be used to measure radiated emissions from an EUT. See basic standard IEC 61000-4-21 [I6.7]. The measurement is performed by rotating one or more stirrers (metallic paddle wheels) in steps over a complete rotation. An overview of the RVC facility for radiated emission measurements is depicted in Figure I.4. IEC 61000-4-21 contains the measurement method (Annex E), calibration procedure (Annex B) and relevant background information (Annex A).

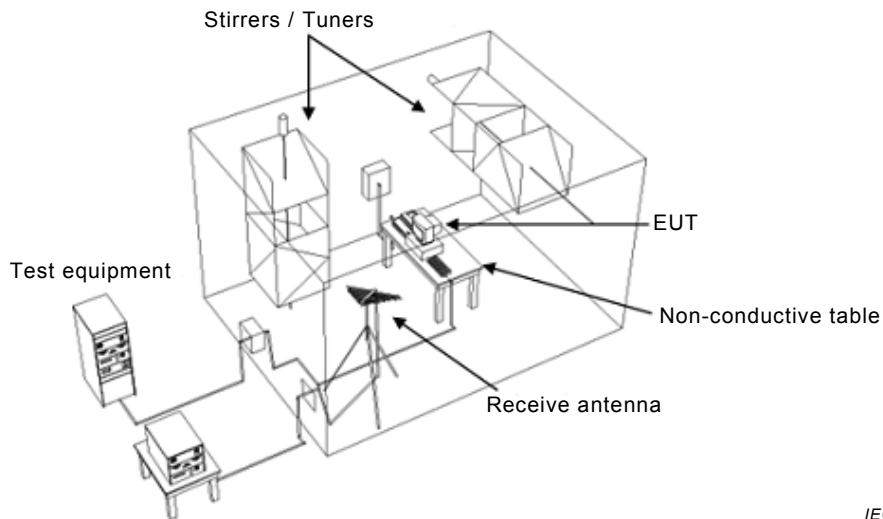

IEC

Figure I.4 – Overview of the reverberation chamber for radiated emission measurement

The EUT should be placed in the calibrated test volume of the RVC; typically the EUT will be placed in the centre of the test volume. The EUT arrangement (including cable routing) in the RVC should be the same as applicable for the SAC as shown in D.1.1 and Clause D.3 for tabletop, floor standing, or combined EUTs.

Uncertainty considerations for the RVC method can be found in reference [I6.6].

I.6 Reference documents

- [I6.1] B. Loader et al, *The Longitudinal Field in the GTEM 1750 and the nature of the termination*, Proceedings EMC Europe, Sorrento, Italy. Sept 2002
- [I6.2] S. Ishigami, K. Harima, Y. Yamanaka, *Theoretical evaluation of the condition of EUT installation in a GTEM cell*, The Transactions of the Institute of Electronics, Information and Communication Engineers B, Vol. J86-B, No. 7, 2003, pp.1183-1190

- [I6.3] T. Loh et al, *A method to minimize emission measurement uncertainty of electrically large EUTs in GTEM cells and FARs above 1 GHz*, NPL UK. IEEE Trans EMC Nov 2006
- [I6.4] A. Nothofer et al, *The Use of GTEM Cells for EMC Measurements*, NPL and York EMC UK, Measurement Good Practice Guide No 65 Jan 2003
- [I6.5] IEC 61000-4-20:2010, *Electromagnetic compatibility (EMC) – Part 4-20: Testing and measurement techniques – Emission and immunity testing in transverse electromagnetic (TEM) waveguides*
- [I6.6] L.R. Arnaut, NPL Report TQE 2, *Measurement uncertainty in reverberation chambers – I. Sample statistics*, Ed. 2.0, December 2008
(http://publications.npl.co.uk/npl_web/pdf/TQE2.pdf)
- [I6.7] IEC 61000-4-21:2011, *Electromagnetic compatibility (EMC) – Part 4-21: Testing and measurement techniques – Testing and measurement techniques – Reverberation chamber test methods*
- [I6.8] ANSI C63.4-2009 *American National Standard for Methods of Measurement of Radio-Noise Emissions from Low-Voltage Electrical and Electronic Equipment in the Range of 9 kHz to 40 GHz*.

Bibliography

CISPR 13:2009, *Sound and television broadcast receivers and associated equipment – Radio disturbance characteristics – Limits and methods of measurement*

CISPR 16 (all parts), *Specification for radio disturbance and immunity measuring apparatus and methods*

CISPR TR 16-3, *Specification for radio disturbance and immunity measuring apparatus and methods – Part 3: CISPR technical reports*

CISPR TR 16-4-3:2004, *Specification for radio disturbance and immunity measuring apparatus and methods – Part 4-3: Uncertainties, statistics and limit modelling – Statistical considerations in the determination of EMC compliance of mass-produced products*
CISPR TR 16-4-3:2004/AMD1:2006

CISPR 22:2008, *Information technology equipment – Radio disturbance characteristics – Limits and methods of measurement*

IEC 60050-161:1990, *International Electrotechnical Vocabulary – Chapter 161: Electromagnetic compatibility*

IEC TR 60083, *Plugs and socket-outlets for domestic and similar general use standardized in member countries of IEC*

IEC PAS 62825, *Methods of measurement and limits for radiated disturbances from plasma display panel TVs in the frequency range 150 kHz to 30 MHz*

ISO IEC 11801, *Information technology – Generic cabling for customer premises*

ITU-R BT 471-1:1986, *Nomenclature and description of colour bar signals*

ITU-R BT 1729:2005, *Common 16:9 or 4:3 aspect ratio digital television reference test pattern*

ANSI/SCTE 07:2000, *Digital Video Transmission Standard for Television*

ARIB STD-B1, *Digital Receiver For Digital Satellite Broadcasting Services Using Communication Satellites*

ARIB STD-B21, *Receiver For Digital Broadcasting*

ARIB STD-B20, *Transmission system for digital satellite broadcasting*

ARIB STD-B31, *Transmission System for Digital Terrestrial Television Broadcasting*

ATSC Standard A/53, *Digital Television Standard*

ATSC Standard A/65, *Digital Television Standard, programme and system information protocols*

ATSC Standard 8VSB, *8 level vestigial side band modulation specification*

EN 300 421, *Framing structure, channel coding and modulation for 11/12 GHz satellite services*

EN 300 429, *Framing structure, channel coding and modulation for cable systems*

EN 300 744, *Framing structure, channel coding and modulation for digital terrestrial television*

ES 201 488, *Data-Over-Cable Service Interface Specifications Radio Frequency Interface Specification*

ES 202 488-1, *Access and Terminals (AT): Second Generation Transmission Systems for Interactive Cable Television Services – IP Cable Modems – Part 1: General*

ETSI TS 101 154 V1.5.1:2004-05, *Digital Video Broadcasting (DVB); Implementation guidelines for the use of Video and Audio Coding in Broadcasting Applications based on the MPEG-2 Transport Stream*

ETSI TR 101 154, *Implementation guidelines for the use of MPEG-2 Systems, Video and Audio in satellite, cable and terrestrial broadcasting applications*

IEEE Standard 1284-1, *IEEE Standard for Information Technology & Transport Independent Printer/System Interface (TIP/SI)*

IEEE Standard 1394, *IEEE Standard for a High Performance Serial Bus – Firewire*

JCTEA STD-002, *Multiplex System for Digital Cable Television*

JCTEA STD-007, *Receiver for Digital Cable Television*

British Standards Institution (BSI)

BSI is the national body responsible for preparing British Standards and other standards-related publications, information and services.

BSI is incorporated by Royal Charter. British Standards and other standardization products are published by BSI Standards Limited.

About us

We bring together business, industry, government, consumers, innovators and others to shape their combined experience and expertise into standards-based solutions.

The knowledge embodied in our standards has been carefully assembled in a dependable format and refined through our open consultation process. Organizations of all sizes and across all sectors choose standards to help them achieve their goals.

Information on standards

We can provide you with the knowledge that your organization needs to succeed. Find out more about British Standards by visiting our website at bsigroup.com/standards or contacting our Customer Services team or Knowledge Centre.

Buying standards

You can buy and download PDF versions of BSI publications, including British and adopted European and international standards, through our website at bsigroup.com/shop, where hard copies can also be purchased.

If you need international and foreign standards from other Standards Development Organizations, hard copies can be ordered from our Customer Services team.

Copyright in BSI publications

All the content in BSI publications, including British Standards, is the property of and copyrighted by BSI or some person or entity that owns copyright in the information used (such as the international standardization bodies) and has formally licensed such information to BSI for commercial publication and use.

Save for the provisions below, you may not transfer, share or disseminate any portion of the standard to any other person. You may not adapt, distribute, commercially exploit or publicly display the standard or any portion thereof in any manner whatsoever without BSI's prior written consent.

Storing and using standards

Standards purchased in soft copy format:

- A British Standard purchased in soft copy format is licensed to a sole named user for personal or internal company use only.
- The standard may be stored on more than one device provided that it is accessible by the sole named user only and that only one copy is accessed at any one time.
- A single paper copy may be printed for personal or internal company use only.

Standards purchased in hard copy format:

- A British Standard purchased in hard copy format is for personal or internal company use only.
- It may not be further reproduced – in any format – to create an additional copy. This includes scanning of the document.

If you need more than one copy of the document, or if you wish to share the document on an internal network, you can save money by choosing a subscription product (see 'Subscriptions').

Reproducing extracts

For permission to reproduce content from BSI publications contact the BSI Copyright and Licensing team.

Subscriptions

Our range of subscription services are designed to make using standards easier for you. For further information on our subscription products go to bsigroup.com/subscriptions.

With **British Standards Online (BSOL)** you'll have instant access to over 55,000 British and adopted European and international standards from your desktop. It's available 24/7 and is refreshed daily so you'll always be up to date.

You can keep in touch with standards developments and receive substantial discounts on the purchase price of standards, both in single copy and subscription format, by becoming a **BSI Subscribing Member**.

PLUS is an updating service exclusive to BSI Subscribing Members. You will automatically receive the latest hard copy of your standards when they're revised or replaced.

To find out more about becoming a BSI Subscribing Member and the benefits of membership, please visit bsigroup.com/shop.

With a **Multi-User Network Licence (MUNL)** you are able to host standards publications on your intranet. Licences can cover as few or as many users as you wish. With updates supplied as soon as they're available, you can be sure your documentation is current. For further information, email cservices@bsigroup.com.

Revisions

Our British Standards and other publications are updated by amendment or revision.

We continually improve the quality of our products and services to benefit your business. If you find an inaccuracy or ambiguity within a British Standard or other BSI publication please inform the Knowledge Centre.

Useful Contacts

Customer Services

Tel: +44 345 086 9001

Email: cservices@bsigroup.com

Subscriptions

Tel: +44 345 086 9001

Email: subscriptions@bsigroup.com

Knowledge Centre

Tel: +44 20 8996 7004

Email: knowledgecentre@bsigroup.com

Copyright & Licensing

Tel: +44 20 8996 7070

Email: copyright@bsigroup.com

BSI Group Headquarters

389 Chiswick High Road London W4 4AL UK